



**A Guide to Better**

**Public Toilet**

**Design and Maintenance**



**A Publication by the Restroom Association (Singapore)**

<b>CONTENTS</b>	<b>PAGE</b>
<b>Definition of “A Well-Designed Toilet”</b>	<b>1</b>
<b>I Design</b>	<b>2</b>
1.0 Introduction	2
1.1 Layout	2
1.2 Lighting	5
1.3 Materials	6
1.4 Urinals	8
1.5 Water Closets (WCs)	9
1.6 Wash Basins and Taps	10
1.7 Provision of Facilities	12
1.8 Special Needs and User-Friendly Features	15
1.9 Ventilation System	16
1.10 Looscaping	18
1.11 Security and Vandalism Measures	18
1.12 Installation Standards	20
1.13 Installation for Smart Technology	22
1.14 SPF Safe Toilets (Safe Toilets)	22
<b>II Maintenance</b>	<b>23</b>
2.0 Introduction	23
2.1 Sequence of Cleaning	24
2.2 Scheduled Cleaning	26
2.3 Timing and Frequency of Cleaning	26
2.4 Basic Equipment and Supplies	27
2.5 Correct Use of Cleaning Agents	27
2.6 Green Cleaning Agents	28
2.7 Mechanical Ventilation System	28
2.8 Training	28
2.9 Outcome-Based Contracting	29
2.10 Selecting a Cleaning Service Provider	29
2.11 Technology for Effective Cleaning and Maintenance	30
2.12 Singapore Green Building Product Certification Scheme	34
2.13 National Environment Agency’s Enhanced Clean Mark Accreditation Scheme	35
<b>III User Education</b>	<b>36</b>

# **A Guide to Better Public Toilet Design and Maintenance**

Sixth Edition 2025

3.0	Influencing Good User Behaviour	36
3.1	Toilet Educational Materials	37
3.2	Public Outreach	40
<b>ILLUSTRATIONS</b>		<b>41</b>
<b>APPENDICES</b>		<b>60</b>
<b>ACKNOWLEDGEMENTS</b>		<b>109</b>

## **Definition of “A Well-Designed Toilet”**

Anyone, who has ever been in an overcrowded or uncomfortable public toilet, will value a good toilet design. The usual demands placed on a high-profile, high traffic and heavily used facility requires extra thoughts for each process. A well-designed public toilet has to be:

- (a) Clean and dry
- (b) Well ventilated
- (c) Easy to maintain
- (d) Carefully planned layout
- (e) Friendly to persons with disabilities and special needs

There are various types of toilets:

1. Public toilets provided by shopping centres including the floor in commercial buildings with shops, supermarkets, wet markets, eating establishments & food centres, restaurants, coffeeshops, hawker centres, food courts, bars, nightclubs, discotheques, pubs, conference halls, cinemas, theatres, convention halls, exhibition halls, parks & park connectors, bus terminals & interchanges, MRT stations, petrol stations, stadiums and public swimming pools. Use of these facilities is generally open to any member of the public or restricted to the patrons of the owner of the facility, regardless of payment/ non-payment to access the premises.
2. Private toilets in offices, factories or occupants of buildings where the use is restricted to staff or patrons of the service provider or by the building management.
3. Private Residences (This is beyond the scope of this guidebook).

Public toilets are places where one is obliged to ease oneself in unfamiliar surroundings among the strangers of the same sex. Therefore, the fundamental principles of design of toilets include psychological studies and not just physical clearances and space requirement. While the National Environment Agency's (NEA) Code of Practice on Environmental Health (COPEH) stipulates the minimum basic design criteria to address environmental health concerns, this Guide covers some of the best practices and good examples of toilet design that look beyond environmental health concerns such as user convenience and satisfaction.

# **I Design**

## **1.0 Introduction**

A number of different activity spaces are shown in the diagram (See [Illustration 1](#)): space occupied by the appliances itself, additional space required by the user and further space for their own belongings or circulation within the toilets. In many cases, these latter spaces may overlap on occasion. Common sense will dictate when this is appropriate and when it is not.

Placing the appliances in order of use simplifies the circulation and reduces the distance travelled by the user. Public toilets should be designed to minimise hand contact as far as possible for hygienic reasons. Electronic products for toilets such as flush valves and faucets require minimum maintenance but offer enhanced operations that promote sanitation and perceived cleanliness because of hands-free operation. Therefore, using sensor-operated appliances should encourage hygiene.

It is difficult and costly to insulate the toilets acoustically and this problem can be resolved by planning isolation as much as possible.

No unsupervised installation can prevent vandalism. Even with the most vandal resistant appliances, an unsupervised facility will eventually become sub-standard. In most cases, facility engineers and cleaning attendants play an important role, which will result in well-maintained toilets. However, all designs should allow for individual items to be replaced. Pipe work, traps and electrical supplies should be concealed for aesthetic and hygiene reasons.

## **1.1 Layout**

Design symmetrical layout concept for toilet, where space is available, so as to reduce disruption to toilet usage during cleaning maintenance e.g. allow half of the toilet to be closed for maintenance while keeping the other half open for use.

## **A Guide to Better Public Toilet Design and Maintenance**

### **Sixth Edition 2025**

#### **(a) Entrances**

Single entrance/exit plans work satisfactorily provided the path of the users do not cross each other and the main entrance is wide enough. Dispensing with the main entrance door to the public toilet not only helps to improve the ventilation within the toilet but also minimises hand contact for hygiene reasons (See [Illustration 2](#)).

However, the cubicles, urinals and mirrors shall be away from the line of sight from the main entrance. For example, the door can be replaced by offset entrance maze which blocks the view yet allows easier, hands-free access. For toilets unable to incorporate labyrinth entrances but with sufficient space, installation of hands-free or sensor-operated doors is recommended.

For installation of main entrance without doors, there are several screening arrangements showing the visibility from outside in each case (See [Illustration 3](#)). Consideration should be given to the positioning of the mirrors and to the gaps created by the hinges. For example, the access entrance to male public toilets should not open directly to the urinal area. Avoid entrances opening onto a wall surface with the mirror reflecting the urinals. (See [Illustration 4](#))

#### **(b) Signage**

##### **(i) Design**

Clear signage should be designated for each gender of required public toilet facilities. The design of signage should be of a commonly recognised female and/or male figure in dark colour contrasted on a light background. Signage should be easily seen and distinguished by persons with visual disabilities and the aged. Fancy signages using “Queen” and “King” or “Hat”, “High-heel shoes” are confusing, and are thus not encouraged.

##### **(ii) Placement**

The location of the signs should be near the entrance to each toilet facility and clearly displayed at noticeable locations in main traffic passageways to direct the public to the toilets. Signage should indicate the distance or time e.g. 100m or 5 minutes from the current location to the nearest toilet.

## **A Guide to Better Public Toilet Design and Maintenance**

**Sixth Edition 2025**

### **(iii) Contact and Information**

Clear signage should be displayed within the toilet indicating the name of cleaning attendant and/or cleaning company and scheduled toilet cleaning time(s). Clear signage should also be displayed to help toilet users report faulty water and sanitary fittings and water leakage. Such signage shall contain the name and contact details of the toilet management to whom the user can report for quick remedial action.

### **(iv) Accessible Toilet**

Directional signages leading to accessible toilets should meet the requirements specified in Building and Construction Authority's (BCA) Code on Accessibility in the Built Environment (See [Illustration 5](#)). Visit BCA's website at [www.bca.gov.sg](http://www.bca.gov.sg) for the latest Code.

### **(c) Sanitary Fittings**

Toilet owners and operators should design and plan for the provision of toilets such that sufficient facilities are provided based on the highest expected toilet use. In large facilities, toilets should be provided at every floor (e.g. shopping mall) and uniformly distributed (e.g. stadium).

The ratio of fittings in male and female toilets should take into consideration the expected user profile. Where equal numbers of both genders are expected, there should be proportionately higher number of fittings in the female toilets, such as the minimum numbers specified in NEA's COPEH.

NEA's COPEH also stipulates that sanitary and water appliances and fittings installed in public toilets shall be of heavy-duty classification and quality and shall be easily-cleaned.

As far as possible, fixtures such as urinals and water closets (WCs) should be fitted back-to-back with common pipe ducts in between.

### **(d) WC Cubicles**

According to the NEA's COPEH, WC cubicles shall be at least 900mm (width) x 1500mm (length). Cubicles should be provided with easily closable free-swinging

# **A Guide to Better Public Toilet Design and Maintenance**

**Sixth Edition 2025**

doors. Doors should be fitted with latches, sliding dead-bolts or other similar locking devices. While door locks should be accessible from the inside only, authorised outside key access may be necessary in emergencies or to take an out-of-order cubicle offline. Doors and cubicle partitions should be tightly fitted so as to avoid gaps and openings. Cubicle partitions shall be of rigid design and wall or ceiling hung, where practical, without leg support for easy cleaning of the floor. Wherever possible, all such cubicle partitions should extend to within 50mm from the floor and height of the partitions should extend to at least 2100 mm above the floor level.

A ledge or foldable shelf should be installed in the cubicles for putting personal items. However, the positioning of the ledge or foldable shelf should not be out of view from the user so as to prevent theft of personal items. Refer to 1.11 Security and Vandalism Measures for more details.

## **1.2 Lighting**

A well-designed lighting system will save electrical energy and improve the appearance of the toilet. Poorly designed fixtures with discoloured diffusers go a long way to make a toilet dingy. Dark and shadowy, off-coloured lighting can create the impression that a toilet is not clean.

Natural lighting can be used to help create a softer, friendlier environment. Harsh lighting can create a cold and unwelcoming air while being inappropriate for the tasks being performed. It can also highlight hard-to-clean areas. Thoughtful selection of fixtures and lamps coupled with careful placement is essential (Refer to [Illustration 6 and 7](#) for examples).

All public toilets should be provided with warm-colour lighting for general lighting as well as down lights above the wash basin/mirror (Refer to [Illustration 8](#) for examples). Warm-colour lighting aids in creating a better ambience in the toilets, which in turn encourages more care and responsibility from the users.

According to the NEA's COPEH, the minimum lighting level shall be 300 lux to ensure that areas with water closets, wash basins and urinals are sufficiently illuminated. This

# **A Guide to Better Public Toilet Design and Maintenance**

**Sixth Edition 2025**

minimum lighting level will facilitate thorough cleaning of water closets, wash basins and urinals.

Smart lighting sensors can also be installed. When there is no human movement, movement sensors in LED lightings will automatically dim the lightings from 300 lux to 50 lux instead of total darkness. This ensures it is energy saving without compromising on safety.

The provision of emergency illumination devices is also necessary to illuminate the path of egress for occupants to exit the toilet safely.

Please refer to [section 1.11](#) for more details on security and vandalism measures on lighting.

## **1.3 Materials**

Toilet owners and operators should first determine their toilet renovation cycle before deciding on the type of materials used. For example, a toilet to be renovated every five years should have materials which are durable to last for at least 5 years and resistant to vandalism. Materials used should be durable, easy to maintain and resistant to vandalism and neglect. Applied finishes such as paint should be avoided. For all wall finishes, it shall be of materials which are impervious, durable such as ceramic tiles and phenolic panels etc which can facilitate cleaning and resource conservation (such as minimising the use of water and cleaning agents). This also applies to floors, which shall be constructed of waterproof non slip surfaces like ceramic tiles, natural stone, homogeneous tiles, terrazzo or other impervious materials, so as to facilitate cleaning and resource conservation.

Tiles are good options for floors and walls as they are durable, easy to clean and water resistant. Stain resistant tiles are easier to maintain and clean, hence improving productivity and durability. Careful selection of durable tiles also ensures that the surface quality will not be compromised by heavy traffic or frequent washing and exposure to cleaning liquid.

Examples of good materials: -

## **A Guide to Better Public Toilet Design and Maintenance** **Sixth Edition 2025**

- (a) Floor  
Non-slip ceramic tiles, natural stone, homogeneous tiles, terrazzo.
- (b) Wall  
Ceramic tiles, natural stone, homogeneous tiles, stainless steel, enamelled steel panels, glass block, aluminium panels, phenolic cladding.
- (c) Ceiling  
Mineral fibre board, fibrous plaster board, Aluminium panels or strips

Floor finishes are available in a wide variety of materials. The finishes must be sufficiently durable to withstand the anticipated traffic levels and the toilet-cleaning frequency should also be sufficient to keep the floor looking well maintained and clean.

The walls should be tiled, allowing the cleaning attendants to sponge down the walls and floors thoroughly with little difficulty. Another alternative is to use ceramic tiles or wall cladding.

Wall and floor tiles of large surface areas are encouraged for easy maintenance. The tile size should be at least 100mm by 200mm.

Walls within 610mm of urinals and water closets should have a smooth, hard, non-absorbent surface to a height of 1200mm above the floor, and except for structural elements, the type of materials used in such walls should be resistant to moisture. Building and Construction Authority's (BCA) building codes would need to be considered.

The most common type of ceiling finishes includes calcium silicate board and suspended ceiling tiles. If there is piping above the ceiling, for example, suspended tiles will permit easy access for maintenance and are more easily repaired in the event of spot damage. Calcium silicate board may be better suited for applications where access above the ceiling is not required. When the time comes for renewal of ceiling finishes, it is far less expensive to repaint calcium silicate board than to replace ceiling tile.

## **A Guide to Better Public Toilet Design and Maintenance** **Sixth Edition 2025**

Use colours to brighten the toilet, create interest, and produce a conducive environment.

Colour, achieved with materials and lighting, is one of the vital ingredients in creating ambience. It can be part of the tile or stone finishes, or added to the applied finishes such as the enamelling on steel or aluminium. If paint is to be used, it should be restricted to areas that are out of reach, e.g. ceilings.

Please refer to [section 1.11](#) for more details on security and vandalism measures.

### **1.4 Urinals**

Only urinal flush valves and waterless urinals (refer to [section 2.11 \(d\)](#)) registered under PUB's Mandatory Water Efficiency Labelling Scheme (MWELS) shall be installed. Visit the PUB's website at [www.pub.gov.sg](http://www.pub.gov.sg) for more details.

All urinal flush valves shall be fitted with a sensor-operated flush valve coupled with manual override feature. A urinal sensor-operated flush valve is a valve with an electronic control device that is automatically actuated to supply a predetermined quantity of not more than 1 litre of water per flush after each use.

A urinal manual override is a built-in feature in the urinal sensor-operated flush valve to allow the user to manually actuate an immediate flushing of the urinal by pressing a button. The sensor and the manual override will not function in the event of a power supply failure. When the override button is used, the manual override feature overrides the sensor operation and discharges only a preset volume of water (not more than 1 litre of water per flush) even if the button continues to be held actuated.

No second flush shall be activated when the user leaves the urinal.

Individually wall-hung full-length urinal units (See [Illustration 9](#)) shall be installed and be at least 300mm wide and the lip of the collection area projecting from the wall by at least 300mm.

A urinal should not be set closer than 450mm from its centre to any side wall, partition, vanity or other obstruction, or closer than 900mm centre-to-centre between adjacent fixtures. There should be at least a 900mm clearance in front of the urinal to any wall,

# A Guide to Better Public Toilet Design and Maintenance

Sixth Edition 2025

fixture or door. (See [Appendix I](#)). Urinals should be separated by modesty boards of not less than 300mm x 1800mm (Height) to act as a visual barrier between urinals. The modesty boards should be high enough to block the view of other users. However, it should not extend right down to the floor to facilitate cleaning accessibility. The presence of modesty boards will reduce the likelihood of shy patrons using the WCs and thus reduces the occurrences of staining the toilet seat (See [Illustration 9 and 10](#)). Handrails or grab bars should also be provided for at least 1 urinal.

As a further enhancement to keep the urinal areas dry, scupper drains or stainless-steel grating over the drainage could be installed below the urinal bowls. (See [Illustration 11](#)). The scupper drain/ stainless steel grating over drainage shall be placed along the wall beneath the urinals with a maximum width of not more than 150 mm.

Litterbins (See [Illustration 12](#)) with covers operated without hand contact e.g. foot pedal or electronic motion sensor devices should also be provided near urinals for users who need to wash and clean up with tissue paper after urinating. The provision of litterbins near urinals also prevents choking of the urinals due to possible disposal of tissue into the urinals by the users.

Urinals can also be designed to facilitate aiming such as pictures of insects in urinals and foot prints or contrasting-coloured tiles on the floor to encourage users to stand closer. This will help to keep the floor dry and prevent drips.

## 1.5 Water Closets (WCs)

Pedestal (sitting) type WCs shall preferably be wall hung, without leg support, so as to facilitate cleaning. Installation of squatting type WC pans in all cubicles is discouraged so as to cater to the needs of various demographic groups and an ageing population. WCs shall be fitted with a sensor-operated flush valve and coupled with manual by-pass and manual override.

A WC sensor-operated flush valve is a valve with an electronic control device that is automatically actuated to supply a predetermined quantity of not more than 4 litres of water per flush after each use. A WC manual override cum by-pass is a built-in feature in the WC sensor-operated flush valve to allow the user to manually actuate an

## **A Guide to Better Public Toilet Design and Maintenance**

**Sixth Edition 2025**

immediate flushing of the WC by pressing a button. The sensor and the manual override will not function in the event of a power supply failure. The manual by-pass feature will enable the flush valve to continue to function manually in the event of a power supply failure. When the override cum by-pass button is used, the manual override and by-pass features override the sensor operation and discharge only a preset volume of water (not more than 4 litres of water per flush) even if the button continues to be held actuated. No second flush shall be activated when the user leaves the WC. Only WC sensor-operated flush valve registered under PUB's Mandatory Water Efficiency Labelling Scheme (MWELS) shall be installed. Visit the PUB's website at [www.pub.gov.sg](http://www.pub.gov.sg) for more details.

A WC should not be set closer than 450mm from its centre to any side wall, partition, vanity or other obstruction. There should be at least a 900mm clearance in front of the WC to any wall, fixture or door. The shape of WCs should be of the elongated type and equipped with seats of the elongated type. Seats should be constructed of smooth, non-absorbent material. All seats should be of the hinged open front type. Integral seats should be of the same material as the fixture. Seats should be sized properly for the WC bowl type.

If a squatting WC is to be installed; only one should be installed in the cubicle furthest from the main entrance. For cubicles where a squatting WC is provided, grab bars shall be installed. The cubicle should be kerbed such that water will not flow out of the boundary of the cubicle and the cubicle floor shall be properly graded towards the gully/floor trap within the cubicle.

There are materials coated and vortex typed flushing WCs in the market that will aid in more efficient cleaning maintenance and dirt removal.

### **1.6 Wash Basins and Taps**

Wash basins should be substantial in size. The basins should have a minimum size of 500mm in length and 400mm in width, which facilitates hand-washing and minimises splashes.

## **A Guide to Better Public Toilet Design and Maintenance**

**Sixth Edition 2025**

A wash basin should not be set closer than 450 mm from its centre to any side wall, partition, vanity or other obstruction, or closer than 900 mm centre-to-centre between adjacent fixtures. There should be at least a 900 mm clearance in front of the wash basin to any wall, fixture or door. (See [Appendix II](#))

Wash basins can be installed into vanity tops, and located beneath the vanity as shown in [Appendix II](#) and [Illustration 13](#). If vanity tops are provided, it should have backsplash and apron edges as shown in [Appendix III](#) and [Illustration 14](#).

If standalone wash basins are installed without vanity tops, it should have provision such as grille for users to place their belongings. Scupper drains with metal grating shall preferably be installed for ease of cleaning and drainage. (See [Illustration 15](#))

The use of flat bottom wash basins is not recommended. Such wash basins do not effectively allow dirt and debris to be washed into the drain pipes. Wash basins shall be under-counter. Other designs such as a long basin trough are allowed provided that they can minimise the problem of water spilling over from the basin to the counter. For basins that sit on top of the counter or are stand-alone, these shall be deep enough to prevent water splashing out of the basins when in use.

In order to keep the toilets dry, the vanity top-cum-wash basins should be installed outside for common use by all users. For high-traffic, wet or vandalism-prone areas such as parks, MRT stations, hawker centres, wet markets and beaches, wash basins should be installed outside the main toilet entrance.

All wash hand basin taps shall be sensor taps, except for 1 which shall be battery operated or chargeable battery-operated sensor type tap, installed per toilet block to ensure that 1 tap remains functional during power supply outage. For toilet block that provide only 1 wash hand basin, only self-closing delayed-action mechanical type tap shall be installed. Please refer to the Public Utilities (Water Supply) Regulations and the Singapore Standard CP 48 - Code of Practice for Water Services for requirements on timings and allowable flow rates for taps. Only basin taps registered under PUB's MWELS shall be installed.

**A Guide to Better Public Toilet Design and Maintenance**  
Sixth Edition 2025

**1.7 Provision of Facilities**

A one-stop provision (See [Illustration 16](#)) of auto sensor tap, auto sensor soap dispenser, litter bin and hand-dryer or paper towel dispenser at wash basin area is strongly recommended to minimise wetting of floors and provide the ease of keeping the toilet clean and dry.

**(a) Soap Dispensers**

Instead of liquid soap, the use of foam soap, which is less soapy, is recommended to reduce water usage and prevent theft. For hygiene purpose, sensor dispensers should be considered. At a minimum, for every 2 count of wash basins, 1 soap dispenser shall be provided. For a long basin trough, 1 soap dispenser shall be provided for every 2 taps. The dispenser shall have a transparent window to clearly indicate the level of soap in the dispenser to assist in timely refilling. Soap dispensers are recommended to be positioned for easy refilling to prevent any potential injuries due to repeated bending and strain by cleaning attendants.

**(b) Provision of Centralised Soap Dispensing Reservoir**

Provide centralised soap dispensing systems that will aid efficient refilling of sensor dispensers and minimise the need for manual refilling of soap dispensers. Please refer to [section 2.11 \(a\)](#) for more details on sensors.

**(c) Litterbins**

Litterbins (See [Illustration 12](#)) shall be provided directly below or in close proximity (preferably located in front of the wash basins) to the wash basins to minimise tiny bits of litter on the floor left behind by users. A sanitary bin (See [Illustration 17](#)) with cover for the disposal of sanitary pads shall be provided in each WC cubicle in female and unisex toilets. Bins shall always be covered and be operated without hand contact e.g. foot pedal or electronic motion sensor devices. The use of bins with fill level sensors will aid in prompt emptying of the litterbins upon reaching predetermined fill levels. Please refer to [section 2.11 \(a\)](#) for more details on sensors.

**(d) Hand-Dryers/Paper Towel Dispensers**

Similar to soap dispensers, at a minimum, 1 hand-dryer or paper towel dispenser shall be provided for every 2 count of wash basins or taps. The hand-dryer shall be positioned directly above or immediately next to the wash basins where practical, and

## **A Guide to Better Public Toilet Design and Maintenance**

**Sixth Edition 2025**

located away from WC cubicles. There are currently fast-drying hand-dryers which are more hygienic and faster in hand drying, thus minimising the wetting of floors. Please refer to [section 2.11 \(d\)](#) for more details on fast-drying hand-dryers.

Paper towel dispensers, if provided, are to be placed directly above and at least between every 2 wash basins. Paper towel dispensers can also minimise the wetting of floors as users are more inclined to use it but the litterbins have to be cleared regularly to prevent overflowing. Paper towel dispensers are recommended in toilets frequented by immuno-deficient persons and where infection control is critical. The use of paper towel dispensers with refill level sensors will aid in prompt refilling of the dispensers upon reaching pre-determined refill levels. Please refer to [section 2.11 \(a\)](#) for more details on sensors.

### **(e) Toilet Paper Dispensers**

Installation of double-roll toilet paper dispensers are recommended so that replacing a roll of toilet paper is done only when it fully runs out. Since there is still another fresh roll of toilet paper to ensure sufficient supply, replacement of toilet paper is not needed even when the quantity of the first roll is low. (See [Illustration 17](#)). Sturdy toilet paper dispensers will also prevent toilet paper wastage with the reduction of rolling speed. The use of toilet paper double roll dispensers with refill level sensors will aid in prompt refilling of the dispensers upon reaching pre-determined refill levels. Please refer to [section 2.11 \(a\)](#) for more details on sensors.

### **(f) Toilet Seat Sanitisers/Covers**

Liquid toilet seat sanitisers or disposable toilet seat covers should be provided in each WC cubicle not only to ensure better hygiene but also prevent toilet paper wastage as without it, users are more likely to place toilet paper over the seat cover.

### **(g) Bidet fixtures within Cubicles**

Bidet fixtures include bidet toilet seats, bidet attachments, and WC with integrated bidet. At least 1 cubicle in the toilet block should be provided with a bidet fixture, and there should be signage on the cubicle door to indicate this. Where WCs with water tap points with spring loaded nozzle are provided, the cubicle should be kerbed such that water will not flow out of the boundary of the cubicle and the cubicle floor shall be

## **A Guide to Better Public Toilet Design and Maintenance**

**Sixth Edition 2025**

properly graded towards the gully/floor trap within the cubicle. There should also be scupper drains with metal grating within the cubicles installed with a water tap point to facilitate the draining off of water.

### **(h) Air Fresheners**

When automatic air freshener sprays are installed, they shall be directed upwards and away from path of users. Apart from air fresheners to counter odour problem, there are also wall-covering materials available which can efficiently traps and neutralises odours. The material is cleanable, stain resistant and long lasting.

Moreover, it can be applied to toilets with wallpaper decorations.

### **(i) WC / Urinal Sanitisers**

The use of cakes, tablets and liquid sanitisers should not interfere with the proper function of the WCs and urinals. It should not be corrosive and should not degrade the surface of the WCs and urinals. The connection of liquid sanitisers to the water supply of the WCs and urinals should not cause contamination of the potable water supply

### **(j) Coat Hooks**

Double hooks (See [Illustration 18](#)) should be affixed behind cubicle doors at a convenient height for all users. The hook should be able to support a minimum of 7 kilograms.

### **(k) Provision of Cleaner Closet/Storerooms**

Provide a cleaner closet/store room on each level for storage of daily-use cleaning tools/equipment, chemicals and supplies. It is recommended to be next or in close proximity to toilets for easier accessibility by cleaners. Store rooms should come with facilities to support washing of cleaning tools, equipment (e.g. sink for filling and emptying cleaning buckets).

### **(l) Separate Screened Areas**

For oral hygiene purposes, a separate screened area (away from the cubicles) can be erected for users to gargle and brush teeth. Alternatively, toilet owners and operators can consider installing cubicle doors that remain closed by default, to minimise the spread of bacteria.

# A Guide to Better Public Toilet Design and Maintenance

Sixth Edition 2025

## 1.8 Special Needs and User-Friendly Features

The application of Universal Design (UD) is to cater to the needs of various demographic groups and persons with different needs. UD, in the broadest term, is “design for all people”. The Building and Construction Authority (BCA) introduced a UD Guide that provides a more complete set of guidelines for adoption in all building designs. Visit BCA’s website at [www.bca.gov.sg](http://www.bca.gov.sg) for more details on the guide.

For toilets, the provision of the following user-friendly features is strongly recommended.

### (a) Accessible Toilet

Location of accessible toilets should not be too remote from the main traffic area to avoid long travel distance. It should be easily accessible for users with urgent need. Where sanitary provisions are to be made for persons with disabilities, such provisions shall be in accordance with the requirements stipulated under BCA’s Code on Accessibility in the Built Environment (See [Illustration 19](#)). Visit BCA’s website at [www.bca.gov.sg](http://www.bca.gov.sg) for the latest Code.

### (b) Toilet for the Ostomates

Ostomates are persons who have had an ostomy, a surgical operation to create an opening in the body for the discharge of body wastes. The facilities are usually installed in accessible toilets. Such facilities for the ostomates are still in the developing process and mostly available at government buildings, airports and train stations in Japan.

Visit Narita International Airport’s website at [www.narita-airport.jp/en/](http://www.narita-airport.jp/en/) for an example.

### (c) Baby Seats

In both male and female toilets, a minimum of one baby seat should be provided in the WC cubicle. Signage should be displayed on cubicle doors to indicate the presence of a baby seat. (See [Illustration 20](#))

### (d) Diaper Changing Stations

## **A Guide to Better Public Toilet Design and Maintenance**

Sixth Edition 2025

Diaper changing stations, benches or tables (See [Illustration 21](#)) should be placed in both male and female toilets where families may utilise the facility.

### **(e) Facilities for Children**

Where there is more than 1 wash hand basin provided, at least 1 shall be installed at a level to accommodate use by children.

In female toilet, a minimum of one urinal with modesty board should be provided for male children accompanied by their female parents/guardians.

In both male and female toilets, a minimum of 1 WC for children should be provided in the WC cubicle. Alternatively, dual adult and child seat cover (See [Illustration 22](#)) can be provided for adult WCs.

### **(f) Signages for Cubicle doors**

Signages (See [Illustration 23](#)) should be displayed on cubicle doors to indicate sit or squat-type WCs. This facilitates the public users to queue up in front of the cubicle for their preferred type of WCs when the toilet is under heavy usage.

### **(g) Full-Length Mirrors**

Full-length mirrors should be provided for proper grooming.

### **(h) Waiting Areas**

Where practical, seats should be provided at waiting areas but it should not obstruct toilet access.

## **1.9 Ventilation System**

Proper ventilation of a public toilet is one of the highest priorities in the design of toilets. An ineffective ventilation system can make a public toilet unbearable, even if it is well designed. An effective ventilation system ensures that vitiated air is quickly extracted, and helps to avoid dampness and subsequent growth of mould on floors and walls. However, the system shall dispel the air directly outdoors without causing any nuisance to neighbouring premises.

# **A Guide to Better Public Toilet Design and Maintenance**

## **Sixth Edition 2025**

### (a) Mechanical Ventilation

Small public toilets should be fitted with an exhaust fan as minimum. Where mechanical means are used for ventilation, using fans (See [Appendix IV](#)) with high efficiency motors and good air-flow rates can help to eliminate air-borne contaminants and odours. This helps to keep the toilets healthier and more hygienic. There should be cross ventilation and the air exchange rate should have a minimum of 20 air changes per hour. Service access ducts, if fully enclosed, shall be connected to the mechanical ventilation system.

The mechanical ventilation system of exhaust fans and, where applicable, ventilation ducts and grilles should ensure that every part of the toilet is within 3m of the fan inlet or an intake grille, measured horizontally. Preferably, intake grilles should also be provided at low levels near the WCs to enable foul-air to be extracted quickly before diffusing into other areas of the toilet.

Where service access ducts are provided, these should be connected to the toilet exhaust ducts to extract air at a rate of 10 air changes per hour. The make-up air to the service access ducts may be taken through extract grilles installed at low level on the walls between the WC compartments and the access duct. (Refer to [Illustration 24](#) for more examples.)

The exhaust air should be discharged to the exterior of the building at a position at least 2 m above the pavement level and at least 5 m from any window or fresh air intake.

Replacement air should be supplied to the toilet to make up for the exhaust air. The replacement air may be taken directly from the exterior, or from adjacent spaces that are permanently air-conditioned or naturally ventilated. The replacement air may be drawn through louvres in the doors, cuttings under the door, or other openings. If replacement air is taken from the exterior, the quantity should be lower than that of the exhaust air so that a lower pressure is created in the toilet, which minimises the possibility of vitiated air entering the adjacent spaces.

Replacement air should preferably be discharged close to the floor level near the wash basins to help keep the floor dry.

**A Guide to Better Public Toilet Design and Maintenance**  
**Sixth Edition 2025**

Air locks should be incorporated to separate the toilet areas from food consumption or preparation areas.

(b) Natural Ventilation

For natural ventilation, suitable fresh air inlet grilles shall be provided to ensure an air exchange rate of 10 air changes per hour.

Natural ventilation should be achieved through windows, doors, louvers or other openings to the outdoors. Such openings should be accessible and controllable by the building occupants. It should also be securable in the event the toilet is prone to vandalism.

### **1.10 Looscaping**

The ambience of public toilets can be enhanced further by:

- (a) Introducing plants which can be easily maintained inside the toilets as well as surrounding the public toilets.
- (b) Placing of wall pictures and illuminated with delicate lighting. The pictures or wallpapers should be waterproof (e.g. made of impervious material).
- (c) Placing of ornaments or sculptures at the 'dead' corners of the toilets.

*Note: For the use of decorations, please refer to [section 1.11 Security and Vandalism Measures \(a\) \(ii\)](#) for avoiding areas of concealment.*

### **1.11 Security and Vandalism Measures**

**(a) Interior**

(i) Lighting

Interior lighting should be provided at all times during operational hours when natural lighting is not available, It should also be bright enough to illuminate

## **A Guide to Better Public Toilet Design and Maintenance**

**Sixth Edition 2025**

entrances, exits, washing areas, cubicle spaces and other areas where the public may be accessing. As a security measure, lighting should be directed at areas of concealment or vandalism-prone areas.

### **(ii) Concealment**

Size of decorations such as live or artificial trees, plants, flowers, etc. should not constitute to areas of concealment. Attention should be paid to avoid areas of concealment when designing public toilets comprising architectural elements such as walls, partitions and ledges.

### **(iii) Graffiti**

Wherever possible, surfaces of walls, vanity tops, toilet cubicle partitions and other surfaces in and around all public toilets should use graffiti resistant materials (e.g. materials including spray paints, markers, etc.), graffiti discouraging decoration and coloration schemes.

### **(iv) Durability**

Durable materials should be used for all fixtures, accessories, and surfaces so as to withstand heavy usage, excessive weight, and possible abuse.

### **(v) Piping**

Wherever possible, all interior water supply and drainage piping connected to fixtures such as WCs and wash basins should be concealed to protect against public contact. Durable materials resistant to human impact should be used for all exposed piping. It should be secured with sturdy fasteners, hangers and supports. There shall be no sharp or abrasive surfaces under wash basins and mop sinks.

### **(vi) Theft Prevention**

When a ledge or foldable shelf is installed in the cubicles for putting personal items, it should not be out of view from the user so as to prevent theft of personal items. The most effective anti-theft measure is the installation of higher partitions between cubicles to prevent adjacent users from committing the theft.

**A Guide to Better Public Toilet Design and Maintenance**  
**Sixth Edition 2025**

**(b) Exterior**

**(i) Lighting**

Exterior lighting should be provided at all times during operational hours when natural lighting is not available. It should also be bright enough to illuminate entrances, exits, washing areas, cubicle spaces and other areas where the public may be accessing and prevent trips or falls.

**(ii) Graffiti**

Exterior surfaces of public toilets should be covered or constructed of durable materials resistant to graffiti (e.g. materials including spray paints, markers, etc.) wherever possible.

**(iii) Security**

During non-operational hours, toilet entrances and windows should be secured by shutters, locks or dead bolts to discourage vandalism.

**1.12 Installation Standards**

Toilet owners and operators shall refer to the NEA's COPEH and BCA's Code on Accessibility in the Built Environment on sanitary provision requirements.

Surface mounting of cables should be avoided and cables should be fully concealed. Sharp corners or edges should be avoided. Covered tiles or PVC strips should be provided along these edges as far as possible. Access panels to pipe ducts should be located as far as possible in inconspicuous areas. Mirrors should be flush with the wall surface.

According to the NEA's COPEH, sanitary and water appliances and fittings installed in public toilets shall be of heavy-duty classification and quality and shall be easily cleaned. Where sanitary provisions are to be made for persons with disabilities, such provisions shall also be in accordance with the requirements stipulated in BCA's "Code on Accessibility in the Built Environment".

For installation standards of the plumbing system and sewerage system, all pipe works should be concealed, except for final connections to the fixtures. Pipe work exposed to view should be chrome-plated. The supply lines and fittings for every plumbing

## **A Guide to Better Public Toilet Design and Maintenance**

**Sixth Edition 2025**

fixture should be installed to prevent backflow. Plumbing fixtures should be installed to facilitate access for cleaning both the fixture and the area around the fixture. Fixtures should be set level and in proper alignment with reference to adjacent walls. For proper planning and design of the sanitary and sewerage system, refer to PUB's website at [www.pub.gov.sg](http://www.pub.gov.sg) for the Code of Practice on Sewerage and Sanitary Works. In addition to the minimum requirements, some good engineering practices in the planning, design and construction of the sanitary and sewerage system are also given in this Code.

All potable water service design and plumbing work shall only be carried out by a water service plumber licensed by PUB. Where the work involves the design of a pumping system or storage tank, a professional engineer registered by the Professional Engineers Board, Singapore shall also be engaged for the design and supervision before the licensed water service plumber can proceed with the work. All potable water service design and plumbing work shall comply with the requirements in the Public Utilities Act, the Public Utilities (Water Supply) Regulations and the Singapore Standard CP48 - Code of Practice for Water Services. The list of water service plumbers licensed by PUB can be found at PUB's website at [www.pub.gov.sg](http://www.pub.gov.sg).

Water fittings shall be those which have been tested for compliance with the relevant standards and requirements stipulated by PUB. For water fittings covered under the PUB's MWELS, only fittings with at least 2-tick or more water efficiency rating shall be installed. The flow rates and flow timings for taps and flush volume requirements for dual-flush low-capacity flushing cisterns and urinals shall be in accordance with the latest Public Utilities (Water Supply) Regulations and Singapore Standard CP 48 – Code of Practice for Water Services. For a list of MWELS water fittings, visit PUB's website at [www.pub.gov.sg](http://www.pub.gov.sg).

For better water efficiency and to qualify as a Water Efficient Toilet under PUB's Water Efficient Building Certification Programme, wash basin taps with 3-tick water efficiency rating should be installed. PUB has developed a Handbook on Application for Water Supply to assist developers, architects, professional engineers, licensed plumbers, government departments and statutory boards in their application for water supply. This Handbook together with the standards and requirements for water fittings stipulated by PUB, fittings, appliances and products registered under PUB's MWELS

## **A Guide to Better Public Toilet Design and Maintenance**

Sixth Edition 2025

and more details on PUB's Water Efficient Building Certification Programme can be found at PUB's website at [www.pub.gov.sg](http://www.pub.gov.sg).

### **1.13 Installation for Smart Technology**

Toilet owners and operators who are keen in the adoption of smart technology are strongly advised to first discuss with their smart technology vendors before commencing any renovation works of their existing toilets or construction works of their new toilets. Some of the smart devices will not only require the wiring of electrical cables but also networking cables. Some products will also require testing prior to installation. Therefore, proper and careful designing of the toilet will ensure the installation of such products does not affect the aesthetic look of the newly renovated or constructed toilet. Please refer to [section 2.11](#) for more details on technology for effective cleaning and maintenance.

### **1.14 SPF Safe Toilets (Safe Toilets)**

In addition to hygiene, accessibility, and user comfort, toilets must also ensure the safety and security of users. The Safe Toilet category, introduced jointly by the Singapore Police Force (SPF) and Restroom Association Singapore (RAS), recognizes toilets that meet essential safety requirements.

#### **Objectives**

- Enhance user confidence and sense of security.
- Deter crime and inappropriate behavior in toilet facilities.
- Prevent voyeurism and related offences.

#### **Assessment Framework**

Safe Toilets are assessed under three categories:

##### **Prevent**

- ✓ Display of crime prevention advisories and posters within the toilet.
- ✓ Public awareness materials to deter potential offenders.

##### **Deter**

# **A Guide to Better Public Toilet Design and Maintenance**

**Sixth Edition 2025**

- ✓ Vent or shaft openings within cubicles must be covered to restrict access and visibility.
- ✓ Floor-to-ceiling cubicle doors and partitions, or extended partitions, should be provided to minimize top/bottom gaps (subject to Singapore Civil Defence Force fire safety compliance).
- ✓ Interior lighting must be sufficient to illuminate entrances, exits, washing areas, cubicles, and urinals during operational hours.

## **Detect**

- ✓ Installation of CCTV cameras covering entrances and exits of toilets to support deterrence and investigations.

### **Voyeurism Prevention (Design Recommendations)**

- 1) Toilet cubicles should prevent potential culprits from reaching above or below partitions.
- 2) For new toilets, floor-to-ceiling doors and partitions are strongly recommended.
- 3) For existing toilets, retrofitting should minimize gaps, with compliance to SCDF fire safety requirements.
- 4) Vent or shaft openings should be fitted with grilles or covers to reduce visibility.

In the Annex, please find examples of Crime prevention advisories (e.g., anti-voyeurism, scam awareness) and Visual reminders placed at entrances and cubicle doors.

## **II Maintenance**

### **2.0 Introduction**

Owners and operators are advised to keep their toilets clean and to ensure that adequate toilet facilities are provided at all times. This will help encourage proper use and promote good public health. Owners and operators are encouraged to refer to the advisory issued by NEA, which is available on their website at [www.nea.gov.sg](http://www.nea.gov.sg).

# **A Guide to Better Public Toilet Design and Maintenance**

## **Sixth Edition 2025**

Preventive servicing such as checking that sanitary fixtures, sensors and mechanical systems are in working condition, oiling of hinges, etc. should be conducted regularly. Toilet owners and operators should also consider having contracts for repair works on standby such that they can be activated on short notice, and preferably to have the requirement for a quick turnaround of 3 working days upon notification. Signage and proper covers for unserviceable sinks/WCs/urinals whilst awaiting repairs should be provided.

### **2.1 Sequence of Cleaning**

General cleaning should be carried out daily. It should follow a systematic sequence to prevent areas, which have been previously cleaned from becoming wet and soiled again before the cleaning process is completed. A systematic sequence will also prevent lapses in the cleaning works. Supervisors and cleaning attendants shall also ensure that water used for cleaning is used efficiently to prevent water wastage and unnecessary wetting of floors, walls, vanity tops, etc to help keep the toilet dry and clean.

The general cleaning should be divided into spot and thorough cleaning. Spot cleaning refers to the process whereby only specific elements of the washroom are cleaned (i.e. those that are soiled). Thorough cleaning refers to the cleaning of the entire washroom and is usually carried out once a day.

The sequence of thorough cleaning should follow the following sequence (NEA developed a pictorial guide as a quick and easy-to-use guide on the right procedures to follow, the correct cleaning agents and tools to use and the use of the right personal protective equipment for safety reasons. A soft copy of the guide (see [Illustration 25](#)) is available on the [NEA's website](#).

- (a) Entrance / Initial Washroom Inspection
- (b) Replenish all consumables
- (c) Clean urinals and toilet bowls

## **A Guide to Better Public Toilet Design and Maintenance**

**Sixth Edition 2025**

- (d) Clean cubicles, vanity-top, mirrors, wash-hand basins, soap dispensers and hand-dryers. Periodic cleaning of walls, fans, ceiling fixtures, etc.
- (e) Clearing litter bins and sweeping the floor
- (f) Damp mop the floor
- (g) Re-instating work area and conduct final inspection

To complement the above pictorial guide, productivity indicator has also been developed as a guide for cleaning service providers and service buyers to estimate the time taken to complete various tasks for washroom cleaning. This enables the cleaning service providers and service buyers to determine the productivity level of a WSQ-trained cleaning attendant. For instance, the time taken to clean a washroom with an estimated area of 25sq metres with 3 toilet bowls and 4 urinal bowls is 39 minutes and 13 seconds. Productivity calculator for washroom cleaning is available for download at [NEA's website](#) at to calculate the productivity level of a trained attendant. The attendant's productivity level can be compared against the productivity indicator to evaluate their performance.

An inspection card should be used in the supervising and monitoring of the daily maintenance of the toilet. This card should be placed at the back of the entrance door to the toilet. A copy of the inspection card is shown in [Illustration 26](#). Alternatively, premises owners and/or cleaning operators may choose to deploy the use of smart technologies in place of an inspection card for ease of supervising and monitoring of toilet maintenance works.

If any errors discovered during the inspection can only be rectified by a qualified person such as a plumber, the building management should be notified immediately. For faulty urinals, while waiting for repair works to be carried out, it should first be fully covered with an "Out-of-order" message clearly displayed to alert users. This applies to other faulty sanitary wares and fittings except the WCs. The cubicle door should be locked with an "Out-of-order" message clearly displayed to alert users.

# A Guide to Better Public Toilet Design and Maintenance

## Sixth Edition 2025

### 2.2 Scheduled Cleaning

Scheduled cleaning should be carried out periodically on a weekly, fortnightly or monthly basis (different surfaces, wares and fittings require different cleaning periods to maintain their cleanliness).

Scheduled thorough cleaning should be carried out during off-peak hours as practical as possible to avoid inconveniencing the user. The periodic cleaning schedule shown in [Appendix V](#) should be adopted.

### 2.3 Timing and Frequency of Cleaning

The timing and frequency of cleaning should be determined by the crowd flow. Thorough cleaning of toilets should be carried out during off-peak hours when toilet usage is low. Touch up cleaning should be done more often during peak hours. Frequency of cleaning is usually determined by expectation and standard of maintenance required by the management of the property and also the budget available for the maintenance of toilets.

The frequency of cleaning should vary for different building types. [Appendix VI](#) should be used as a guide for different building types.

The management of the property should clearly indicate the timing of cleaning (cleaning schedule) of toilet and display the timing at conspicuous spots at the toilets' entrances whereby toilet users may easily view them. An example is appended below.

**A Guide to Better Public Toilet Design and Maintenance**  
Sixth Edition 2025

Toilet Operation Hours

Dear Customers

These toilets will be closed for cleaning at the following times:

**9.00AM to 9.30AM 2.00PM to 2.30PM**

**10.30PM to 11.00PM**

We apologise for any inconvenience caused.

If you have any feedback about our toilets, please approach

our staff for assistance.

Thank you.

## 2.4 Basic Equipment and Supplies

Different equipment for different joints and corners, as well as different cleaning agents and sanitisers, should be used in the cleaning of different sanitary wares and fittings.

To carry out proper toilet maintenance, cleaning attendants should have the equipment listed in [Appendix VII](#).

## 2.5 Correct Use of Cleaning Agents

Cleaning attendants of public toilets should have taken the appropriate Environmental Cleaning Workforce Skills Qualifications (WSQ) course and be equipped with the necessary skills in the proper usage of specific cleaning agents and equipment for different types of materials and finishes in the toilets, e.g. tiles, mirrors, stainless steel. Ideally, the cleaning agent should incorporate protective technology to allow ease of stain removal with repeated usage. A recommended list of the appropriate type of cleaning agents for the different types of finish is shown in [Appendix VIII](#).

# **A Guide to Better Public Toilet Design and Maintenance**

## **Sixth Edition 2025**

### **2.6 Green Cleaning Agents**

The service provider is encouraged to use green cleaning agents to lessen the adverse impact on the environment. The cleaning agents shall be used in accordance to the manufacturers' recommendations with regards to dilution, application and safety precautions. Please refer to Singapore Environment Council (SEC) website at [www.sec.org.sg](http://www.sec.org.sg) for a list of the certified green cleaning agents.

Cleaning agents shall comply with the standard and criteria set by SEC.

### **2.7 Mechanical Ventilation System**

Mechanical ventilation systems should be: -

- (a) Properly maintained to ensure maximum efficiency and optimal operating conditions.
- (b) Checked and serviced on a monthly basis. Cleaning of the systems should also be done weekly via wiping or dusting.

### **2.8 Training**

Washroom cleaning attendants should be properly trained and certified to perform the task well and to meet the enhanced training requirements under the Progressive Wage Model for the Cleaning Sector. The Tripartite Cluster for Cleaners (TCC) has made specific recommendation on the type of WSQ modules that cleaners are required to attain under the Skills Framework for Environmental Services. As part of the recommendation, learners can choose to complete one mandatory WSQ module in Workplace Safety and Health (WSH) and one (1) Core WSQ module under Washroom Maintenance. Visit the website at [www.ntuc.org.sg/tripartiteguidelines](http://www.ntuc.org.sg/tripartiteguidelines) for more details on the TCC report and the list of WSQ courses for the different job roles and levels.

Supervisors should also be trained with the right knowledge and skills not only to effectively supervise the cleaning attendants but also inspect the cleanliness and functionality of the facilities. The Restroom Association (Singapore) or RAS provides training on such inspections. Training is also provided on the use of portable test kits

## **A Guide to Better Public Toilet Design and Maintenance**

Sixth Edition 2025

to inspect and monitor the effectiveness of the cleaning. Visit the RAS' website at [www.toilet.org.sg/on-site-training](http://www.toilet.org.sg/on-site-training) for more details on the training.

### **2.9 Outcome-Based Contracting**

Toilet operators who engage cleaning contractors for toilet cleaning should specify in their contract an outcome-based approach rather than headcount-based outcome. Outcome-Based Contracting (OBC) specifies clear, deliverable outcomes for cleaning contractors and in doing so, encourages them to innovate and be more productive. The outcome-based contract could also stipulate a requirement for trained cleaning attendants (e.g. WSQ certified). Visit the National Environment Agency (NEA) website at <https://www.nea.gov.sg/our-services/public-cleanliness/cleaning-industry/cleaning-industry> for more details on the guides on OBC.

### **2.10 Selecting a Cleaning Service Provider**

Where the toilet cleaning services are to be provided by a third-party cleaning company, the Tripartite Advisory on Best Sourcing Practices and accompanying Step-By-Step Guidebook for Service Buyers provides guidance on choosing and managing the cleaning contractor. For example, the contract can specify the expected performance level and maintenance requirements, such as those mentioned above in this section. This encourages the cleaning contractors to focus on service quality, including providing better employment terms to attract and retain trained cleaning attendants to provide good service. Visit the Ministry of Manpower (MOM) website at <https://www.mom.gov.sg/employment-practices/good-work-practices/best-sourcing-practices> and [NEA website](#) at for more details on the guides on best sourcing and tender evaluation respectively.

The Happy Toilet Programme also serves as an effective gauge on the selection of the cleaning service providers in terms of toilet cleanliness and maintenance. Visit the [Restroom Association \(Singapore\) website](#) for more details on the guide. In order to meet higher star ratings such as 4 Star, 5 Star and 6 Star Happy Toilets, owners are required to adopt Singapore Green Building Council's (SGBC) Singapore Green Building Product Scheme (SGBP) certified products under Public Hygiene Category. Please refer to [section 2.12](#) for more details on SGBP.

**A Guide to Better Public Toilet Design and Maintenance**  
Sixth Edition 2025

**2.11 Technology for Effective Cleaning and Maintenance**

To optimise the use of toilet facilities and enable easier cleaning and maintenance, toilet owners and operators are encouraged to adopt the holistic “Detect Feedback Eliminate Clean (DFEC)” approach. Toilet owners and operators are strongly advised to engage credible smart technology vendors to ensure their products and services are reliable with good technical support. They should always request the vendors to provide their list of clients and attempt to seek feedback from the clients on their products and services. The products and services should preferably be ecofriendly, if applicable. Toilet owners and operators should also carefully evaluate on the types of products to be installed to determine if it is applicable and relevant to their toilets. SGBP certified products are deemed to have met the requirements for durability, efficiency, high performance and holistic sustainability.

(a) Detect

The use of sensors (See [Appendix IX](#)), which acts as an autonomous system, can effectively detect, monitor and feedback any defects or situations such as ammonia, people traffic, lighting levels, abnormal water usage, hand soap, hand towels, toilet paper and litter bins. Some can be rectified through automation while others will alert on demand cleaning needs through notifications. When toilets are not in satisfactory conditions and cannot be rectified through mechanical automation, notification alerts are instantly sent to the owners, operators, facility management crew and cleaning supervisors so that the cleaning crew can be deployed on site to rectify it in the quickest possible time.

The use of sensors can also effectively gather data for useful analytics such as the determination of peak and off-peak usage and forecast cleaning regimes to optimise cleaning crew deployment. The use of sensors not only translates to improved cleaning and maintenance efficiency but also better user satisfaction and lesser reliance on manpower.

Low energy sensors and battery-operated sensors allow for easier retrofitting in existing toilets and lead to lower energy consumption. Use of sensors which are calibrated and are capable of self-calibration are recommended. Sensors

## **A Guide to Better Public Toilet Design and Maintenance**

**Sixth Edition 2025**

should be devoid of any heavy metals or hazardous materials in its composition and product recyclability is encouraged.

(b) Feedback

Defects and any situations, which cannot be effectively monitored by smart sensors, can be complemented with the installation of an interactive feedback system (See [Appendix X](#)). Installation of an interactive feedback system effectively complements the smart sensors in the event that the sensors fail or under servicing and/or maintenance. On the other hand, the installation of sensors also complements the feedback system to monitor the validity of public feedback. An interactive feedback system can provide a simple and intuitive channel for public users to provide feedback on the state of toilet. Any negative feedback received will instantly alert the maintenance management and cleaning crew for any specific follow-up actions in the quickest possible time, thus ensuring the best user experience.

Smart control systems collate feedback received and makes the information available to the owners, operators and cleaning companies through Internet of Things (IoT) enabled applications. The real-time information collected on the performance levels of the cleaning crew can effectively serve as justifications for rewards or improvements. In addition, the smart control system is an extensive data gathering platform that also provides relevant preventive and predictive analytics for owners, operators and cleaning companies using artificial intelligence and machine learning capabilities. The data collected can be used for resource planning and allocation, equipment reliability, cleaning crew's attendance and performance evaluation, number of visitors and other information. The system developed shall also be an open system with the ability to work in conjunction with complementary smart sensors and other smart solutions of other brands in the foreseeable future but at the same time, meet prevailing inter-device communications and security protocol industry standards.

**A Guide to Better Public Toilet Design and Maintenance**  
**Sixth Edition 2025**

(c) Eliminate

Ammonia and odour can be eliminated during toilet cleaning with the use of environmentally-friendly deodorisers such as ionised water. Recent innovations have led to the development of new 3 in 1 compatible product that can perform multiple functions in one step i.e. clean, disinfect and deodorise in one step. With specific product formulations and concentrations of active ingredients, the contact time can be significant reduced from 10 minutes to 30 seconds against SARS-COV-2 viruses.

There are numerous methods to clean, sanitise and disinfect any hard surface. Over the years, new technology has been introduced to help improve the process. Disinfecting solutions that are paired with electrostatic spraying can facilitate disinfecting procedures to become more effective and efficient. Electrostatic spraying has the ability to rapidly and evenly coat hard surfaces with comprehensive coverage, which is more effective than fogging, misting and normal spraying.

The application of infused anti-stain material or self-cleaning protective coatings (See [Appendix XI](#)) on tiles, basins, urinals and WCs can provide a layer of coating to prevent moisture, dirt, grime and oil. Surfaces protected by this coating facilitate cleaning efforts and eliminate the problem of tough stains and graffiti. Some coatings also have an antibacterial feature and it can eliminate microbes which come into contact with the coated tiles and paints. Other antimicrobial coating can stop the growth of disease-causing microorganisms and also increases the surface's durability, appearance and corrosion resistance. All such coatings should last 6 to 12 months per application. Toilet owners and operators are strongly advised to engage credible coating vendors.

The use of paints with mould or microbe resistance helps to enhance the indoor environment. Mould and fungus grow easily in humid environment such as restrooms. Anti-mould or mould-resistant paint offers protection against mould, mildew and fungal attack, prohibiting mould growth on walls and ceiling surfaces ensuring a healthier toilet space.

## **A Guide to Better Public Toilet Design and Maintenance** Sixth Edition 2025

The use of UV-C disinfecting lighting technology (See [Appendix XII](#)), when properly installed can eliminate harmful pathogens both on surfaces and in the air round-the-clock. As a precaution, it is crucial that the design must minimise exposure of UV-C light to people, such as in upper room UV-C installations. Disinfecting lighting technology can be used in poorly ventilated areas or to complement existing mechanical ventilation measures for better protection. The lighting can complement and reduce manual labour requirements for surface disinfection with automation and is free from chemicals.

With the right selection, sustainability can be achieved as follows:

- x Reduction in the amount of chemicals needed to achieve effective disinfection
- x Reduction in water required for rinsing after usage
- x Using water-based systems that have better environmental profiles x Chemicals that are safer to handle for the labour workforce (skin contact and inhalation)
- x Products that have low dilutions in terms of millilitres per litre required – this minimises the cost of applications and reduces plastic containers disposed

### (d) Clean

The adoption of advanced facilities not only helps to save costs but also save resources like paper and water. The use of self-powered taps (See [Appendix XIII](#)) eliminates the need to provide electrical points to power the sensors in the taps. The tap sensors are powered by internally through the previous use of the tap. Running water will create power which is stored in a battery built into the tap. Power from the battery will be used for sensing purposes for next use.

The use of fast-drying and hygienic hand dryers (See [Appendix XIV](#)) can eliminate operational complexity to store, replenish and dispose used towels. Fast-drying hand dryers do not need any heating element which is energy saving and eco-friendly as compared to conventional warm air dryers which are high in energy consumption. Fast-drying hand dryers can be equipped with

## **A Guide to Better Public Toilet Design and Maintenance**

**Sixth Edition 2025**

microbe removal solutions such as UV technology or HEPA filters which traps bacteria and viruses, although these requires replacement periodically. This translates to cleaner air blown onto the hands. Fast-drying hand dryers with drain tanks for collecting waste water require regular cleaning and maintenance. There are hand dryers that allow drying of hands at the wash basin without the need to move to a separate drying area, thus reducing wet floors. Fast drying hand dryers should also meet energy efficiency standards and achieve required air flow rates. This will help in reducing energy consumption for operations. Hand dryers with designs that inhibit dispersal of contaminated air to the surroundings offer a more hygienic and healthier environment.

A waterless urinal requires no flushing of water for its operation. In general, a waterless urinal uses a specially designed replaceable cartridge pre-filled with sealing liquid. The sealant liquid provides an airtight barrier to prevent odours from escaping the waste pipe but allows the urine to pass through because the oil-based sealing liquid is lighter than urine. Modern waterless urinal (See [Appendix XV](#)) uses a vertical sealing membrane type replaceable dry-valve that can withstands both negative and positive pressures to prevent any odours and gases to escape from the waste pipe. There are waterless urinal systems that combine cartridge based (sealant or membrane dry-valve) with microbial (dissolving organic enzymes) to bind urine odour (ammonia), reduce urine deposits and prevents the trap and waste pipe from clogging. When a waterless urinal is installed, it shall be maintained in accordance with the manufacturer's instructions and not cause any odour nuisance and hygiene problem. Only waterless urinals registered under PUB's MWELS shall be installed.

### **2.12 Singapore Green Building Product Certification Scheme**

The Singapore Green Building Product (SGBP) certification scheme is the only industry-centric certification scheme for green building products and materials with a tiered rating system which aims to aggregate and amass a wide selection of green building materials through a comprehensive and holistic methodology. The SGBP scheme is regarded as one of the key standards and benchmarks for green building

## **A Guide to Better Public Toilet Design and Maintenance**

**Sixth Edition 2025**

products in the building and construction industry. As such, the SGBP is well recognised by green building rating programmes which include the Green Mark Scheme, Singapore's national green building rating tool administered by the Building and Construction Authority (BCA).

The SGBP's grounded, science-based methodology enables building products to be impartially evaluated for their relevant, noteworthy qualities, benchmarked against similar products in its category. Building products are assessed on their environmental properties and performance through a comprehensive list of assessment criteria covering the five key areas of Energy Efficiency, Water Efficiency, Resource Efficiency, Health & Environmental Protection and Other Green Features. A certified product's rating level (1-4 ticks) differentiates its environmental and sustainability performance and serves as a testament of the product's environmental commitment. The SGBP certifies products across six main categories, which includes DFEC products intended to achieve the requirements of the Happy Toilet Programme. The Directory of Certified Products can be accessed at <https://web.sgbc.online/public/directory>

### **2.13 National Environment Agency's Enhanced Clean Mark Accreditation Scheme**

The Enhanced Clean Mark Accreditation Scheme (previously known as Voluntary Accreditation Scheme) was launched in 2010, and subsequently enhanced in 2012, to recognise exemplary companies that deliver high standards of cleaning services through training of workers, use of equipment to improve work processes, and fair employment practices. Notwithstanding, service buyers are able to differentiate the standards of cleaning companies before engaging them.

Service buyers who are interested in engaging accredited companies may visit the [NEA's website](#) at for further information.

### **III User Education**

#### **3.0 Influencing Good User Behaviour**

Prior to any forms of user education, it is crucial for toilet owners and operators to strongly commit in adopting good design guidelines so as to provide quality toilets with user-friendly facilities and sufficient amenities i.e. toilet paper and hand soap. Proper training of cleaning attendants in toilet cleaning should also be conducted so as to effectively maintain the toilets the right way. Only with the complete adoption of the above practices can user education be successfully implemented.

Besides providing the right toilet infrastructure, the sections listed below highlighted some tips on influencing good user behaviour.

Section	Page	Ways to Influence Good User Behaviour
1.2 Lighting	7	Warm-colour lighting creates a better ambience in the toilets which encourages more care and responsibility from the users.
1.3 Materials	8	Toilets brightened with colours produce an appealing environment for the users.
1.5 Water Closets	11	Provision of integrated bidet instead of squatted WC pan and hose allows the users to keep the toilets dry.
1.7 Provision of Facilities	14	A one-stop provision of auto sensor tap, soap dispenser, litter bin and hand-dryer or paper towel dispenser at wash basin area can minimise wetting of floors and provide the ease of keeping the toilet clean and dry.
	16	Provision of liquid toilet seat sanitisers or disposable toilet seat covers to prevent users from using excess toilet paper to cover the toilet seat and littering it on the floor.
1.10 Looscaping	21	Decorations could enhance the ambience of the toilet and provide a more conducive environment for the users.

# A Guide to Better Public Toilet Design and Maintenance

Sixth Edition 2025

Having public education messages in the toilets can also help persuade users to do their part in keeping toilets clean.

## 3.1 Toilet Educational Materials

### (a) Message Design

People readily attend to visuals. This makes the use of visuals an important part of the design of the message. Generally, visuals should be

- (i) Simple and uncluttered
- (ii) Attractive
- (iii) Eye-catching

The messages can be either direct or indirect. Direct messages are usually the dos and don'ts while indirect messages are usually thought provoking like fatal consequences mention in (b) (v) below. Another thought-provoking contents can be some of the educational posters (see [Appendix XVI](#)) by RAS to arouse empathy on the challenges faced by cleaning attendants.

### (b) Language Use

The language of public education has to be kept simple. This helps ensure that the message reaches everyone regardless of their educational level. It also ensures that the message is attended to, understood and remembered for future action.

- (i) The reading level (in any of the four official languages) should not be more advanced than that of a Primary Six reader.
- (ii) Jargon, big words, long sentences and negative use of words such as "Don't dirty the toilet" should be avoided. Examples of messages are as follows:
  - x Keep toilet seat clean and dry
  - x Check that the toilet is properly flushed thoroughly after use x
  - Keep the floor clean and dry
  - x Use hand dryer or hand towels
  - x Please put litter into bins

**A Guide to Better Public Toilet Design and Maintenance**  
**Sixth Edition 2025**

- x Aim properly
- x Use amenities with care, etc.

(iii) Slogans can be very effective because they are short, catchy and easy to remember.

(iv) Subtle humour can be used to deal with the personal and sensitive issues surrounding toilet use. Humour can be successfully tapped through cartoon characterizations of toilet fixtures such as wash basin, toilet bowl and litter bin. An additional benefit of cartoon characters is that they can be used with minimal text, reducing the need for translation to other languages.

(v) As the public may not associate dirty toilets with food hygiene and safety, the messages/pictures should adopt the deterrent approach such as showing the fatal consequences of unhygienic practices. Besides reminding users to practise care and consideration when using public toilets, users are also encouraged to leave the toilet clean, dry and sparkling for the next user.

(c) Message Placement

The usual means of message placement in public toilets are posters and stickers. Other means can be the use of display panels or interactive feedback system panels (refer [section 2.11 \(b\)](#)). Audio messages can also be used. The right medium and manner of display should be selected to maximise the effectiveness of the message.

(i) Generally, stickers should be used if:

- x The main purpose of user education is to address specific behavioural concerns such as littering, careless aiming or the flicking of water onto the floor

- x Subtlety is preferred

- x for display, stickers should be:

- ÿ Made of vinyl material, rather than paper.

- ÿ Made with adhesive than can be peeled off without leaving unsightly marks.

## **A Guide to Better Public Toilet Design and Maintenance**

### **Sixth Edition 2025**

• Placed strategically at the spot where the problem behaviour occurs. For example: on the wall above the urinal – to encourage better aiming; At the wash basin area – to discourage flicking of water onto the floor

- (ii) Posters can be used to convey generic messages such as “Help Keep This Toilet Clean, Dry and Sparkling”. Posters should only be used when:
  - x Displayed in a way that makes them repellent to water e.g. Laminated on both sides or protected by acrylic sheets
  - x Mounted with non-marking adhesives. Adhesives such as scotch tape and double-sided tape may damage certain types of wall surfaces and should therefore be avoided.
  
- (iii) Display panels or interactive feedback system panels can be used to display educational messages as follows:
  - x Display panels can be installed in urinals and wash basin areas which can also display a combination of advertisements and educational messages
  - x Interactive feedback system panels can flash educational messages while maintaining its graphical user display
  
- (iv) Audio messages to remind users can also be played as follows:
  - x A combination of music and educational messages
  - x Movement sensors that will trigger automatic playing of educational messages when there is human traffic

#### (d) Provision of Educational Materials

The NEA provides free educational posters to be put up at public toilets. Visit NEA’s website at [www.nea.gov.sg](http://www.nea.gov.sg) for more details.

Free educational materials on water conservation to be put up at toilets can also be obtained from PUB. Visit the PUB’s website at [www.pub.gov.sg](http://www.pub.gov.sg) for more details.

## A Guide to Better Public Toilet Design and Maintenance

Sixth Edition 2025

RAS also provides educational posters (see [Appendix XVI](#)) with messages on hand, foot and mouth disease (HFMD), health hazards, restroom cleaning attendants and fun facts. Visit the RAS' website at <https://www.toilet.org.sg/download> for more details.

### 3.2 Public Outreach

Besides putting up educational materials, the Restroom Association (Singapore) or RAS provides education programmes and talks for preschools schools, organisations and individuals. An educational game called the LOO (Let's Observe Ourselves) Whiz is for downloads at Google Play Store and Apple App Store. It is also available on RAS Facebook page at [www.facebook.com/RestroomAssociation](http://www.facebook.com/RestroomAssociation). Gamers get to experience the demanding work of a restroom cleaning attendant due to poor user behaviour. The purpose of this game is to educate the public to better appreciate the efforts of the restroom attendants by acting responsibly.

The programmes are as follows:

Target Groups	Programmes
Preschools	Happy Toilet School Education for Preschools (HTSE) URL: <a href="http://www.toilet.org.sg/happytoiletpreschool">www.toilet.org.sg/happytoiletpreschool</a>
Primary and Secondary Schools	Sustaining Toilets As Restrooms (STAR) Awards Programme URL: <a href="http://www.toilet.org.sg/starawards">www.toilet.org.sg/starawards</a>
Organisations and Individuals	Eco-Assessor Programme: URL: <a href="http://www.toilet.org.sg/eco-assessor">www.toilet.org.sg/eco-assessor</a>

# **ILLUSTRATIONS**

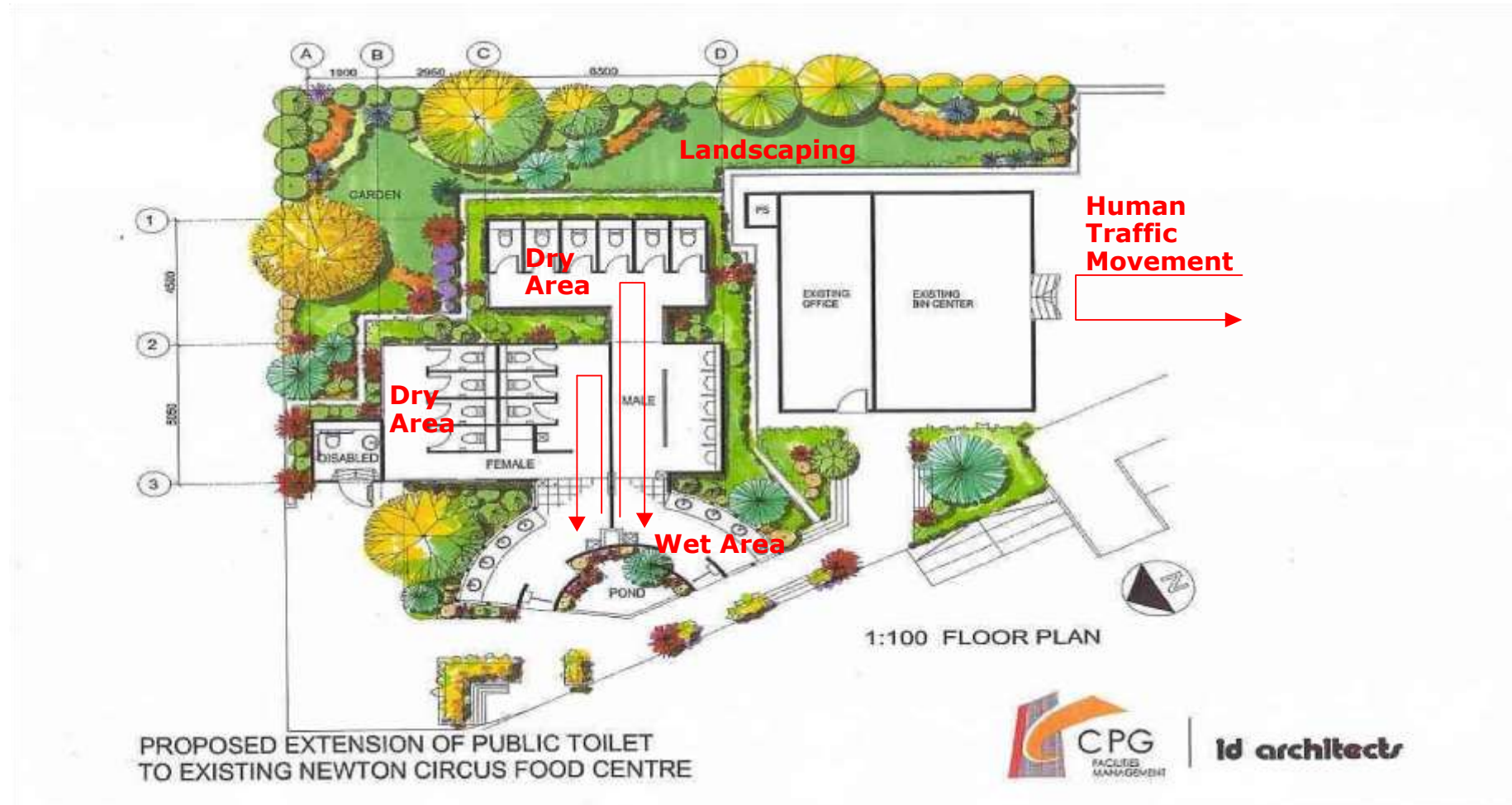
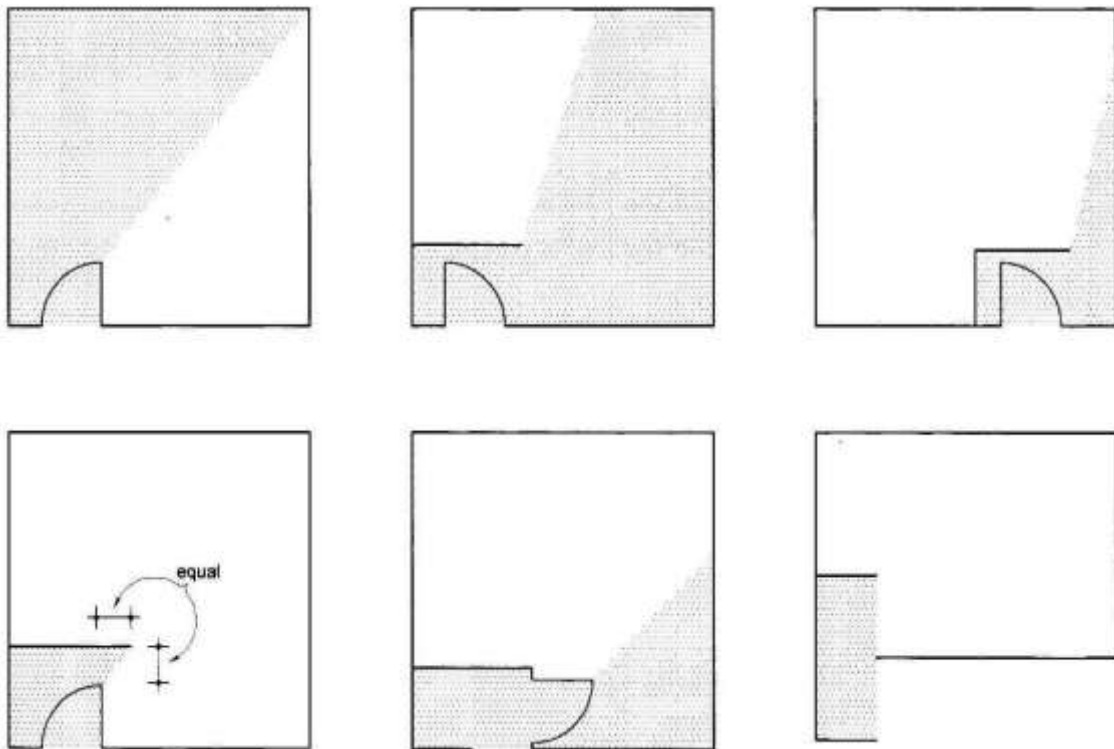


Illustration 1: Space Occupied by appliances, wet areas and dry areas

**A Guide to Better Public Toilet Design and Maintenance**  
Sixth Edition 2025

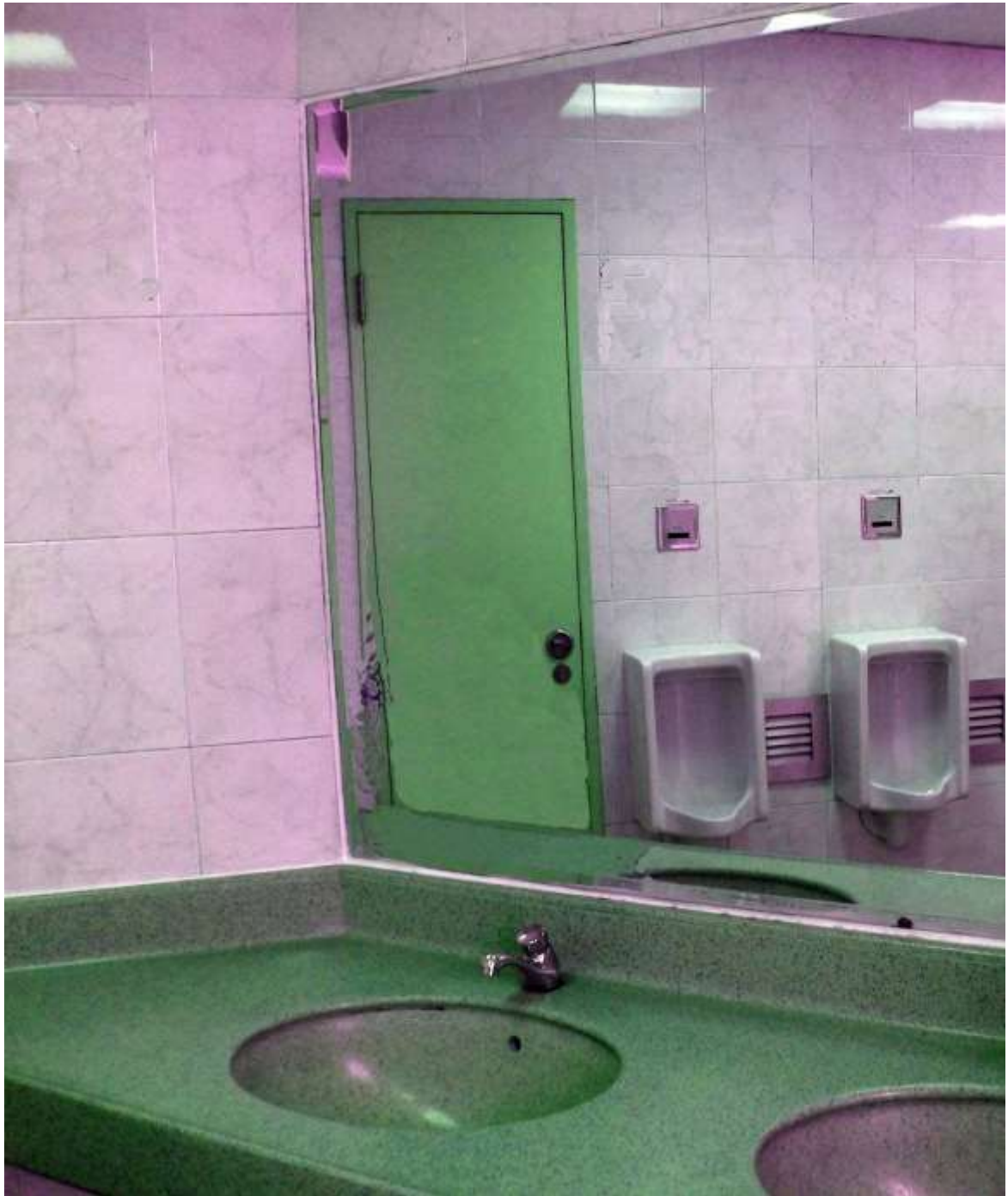


*Illustration 2: Off-set entrance maze without doors*



*Illustration 3: Various Screening arrangements for toilets showing the visibility from external area*

**A Guide to Better Public Toilet Design and Maintenance**  
Sixth Edition 2025



*Illustration 4: Avoid entrances opening onto a wall surface with the mirror reflecting the urinals.*

**A Guide to Better Public Toilet Design and Maintenance**  
Sixth Edition 2025



*Illustration 5: Directional Signages*

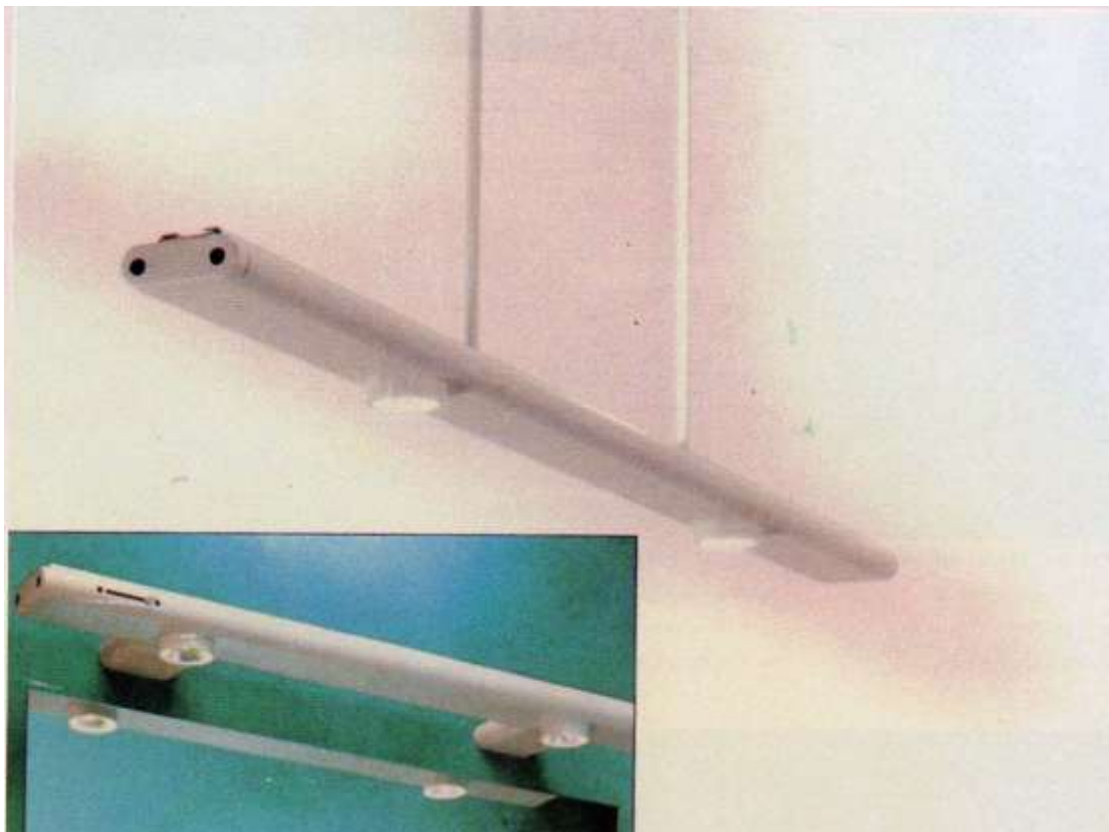


*Illustration 6: Natural Lighting*

**A Guide to Better Public Toilet Design and Maintenance**  
**Sixth Edition 2025**



*Illustration 7: Non-suspended PLC downlight, mounted onto ceiling*



*Illustration 7.1: Suspended fitting for low voltage downlighting and halogen uplighting with the option of twin feeds. All the electrical components are built into the extruded aluminium profile. Finish white, black, yellow, grey and red.*

**A Guide to Better Public Toilet Design and Maintenance**  
**Sixth Edition 2025**

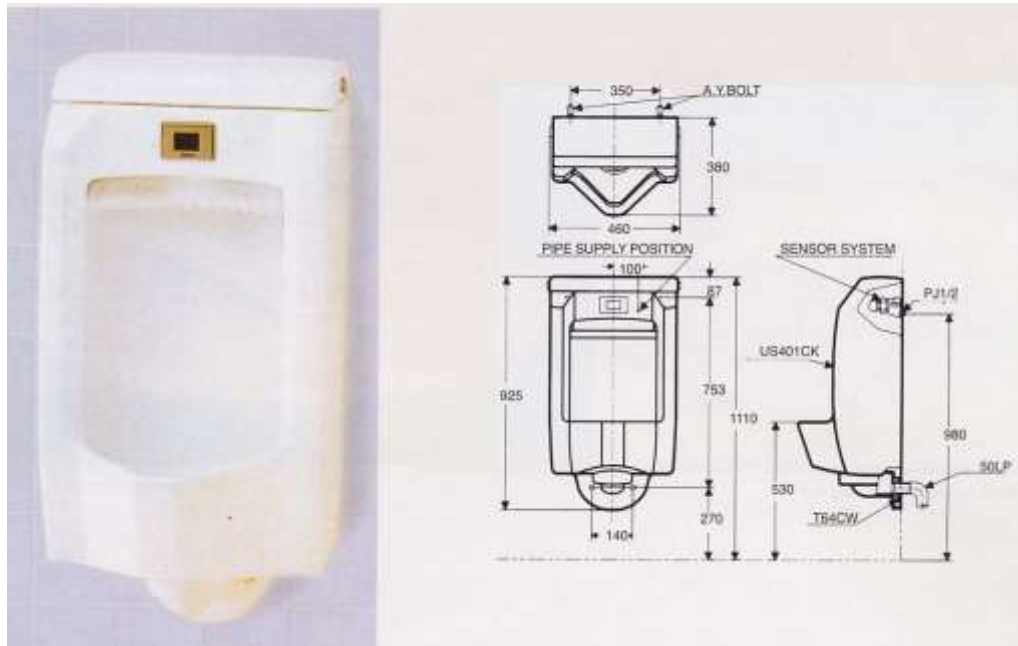


*Illustration 8: Use of warm-colour lighting for general lighting*



*Illustration 9: Wall hung full-length urinals separated by modesty board*

**A Guide to Better Public Toilet Design and Maintenance**  
**Sixth Edition 2025**



*Illustration 10: Wall-hung with built-in-sensor urinal*



*Illustration 11: Adult height and child height urinals, stainless steel grating over drainage*

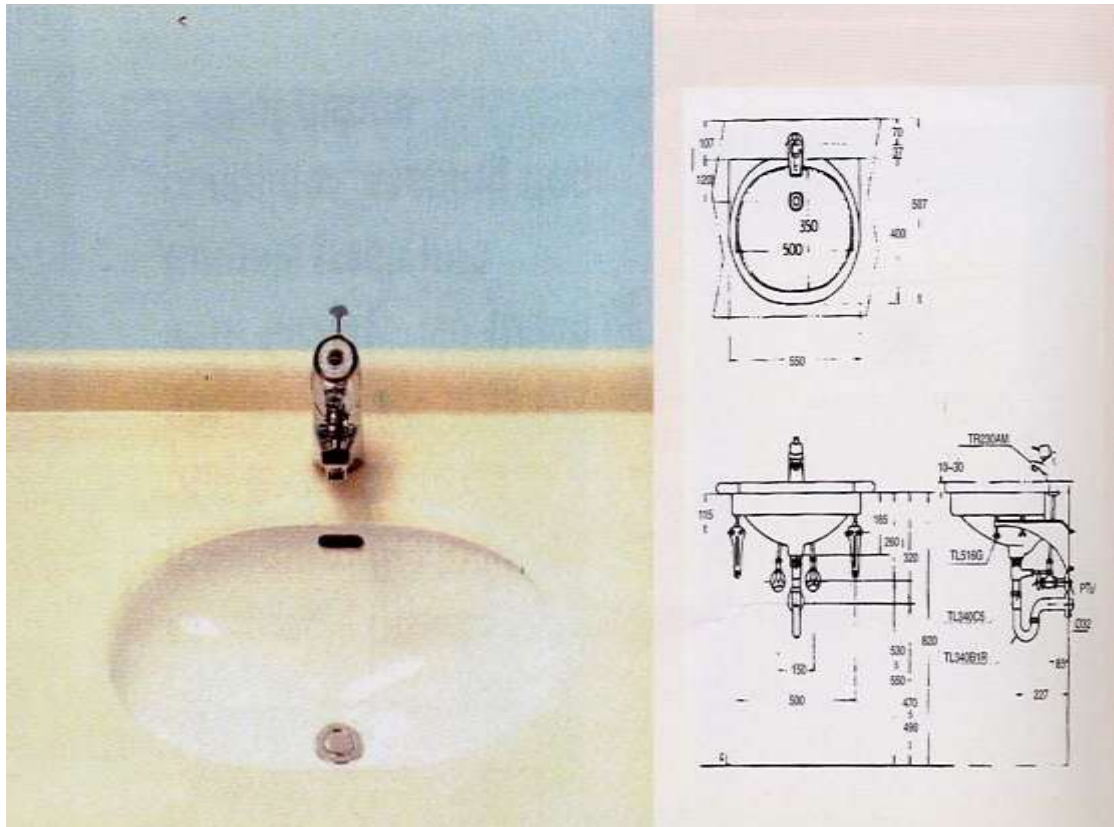
**A Guide to Better Public Toilet Design and Maintenance**  
**Sixth Edition 2025**



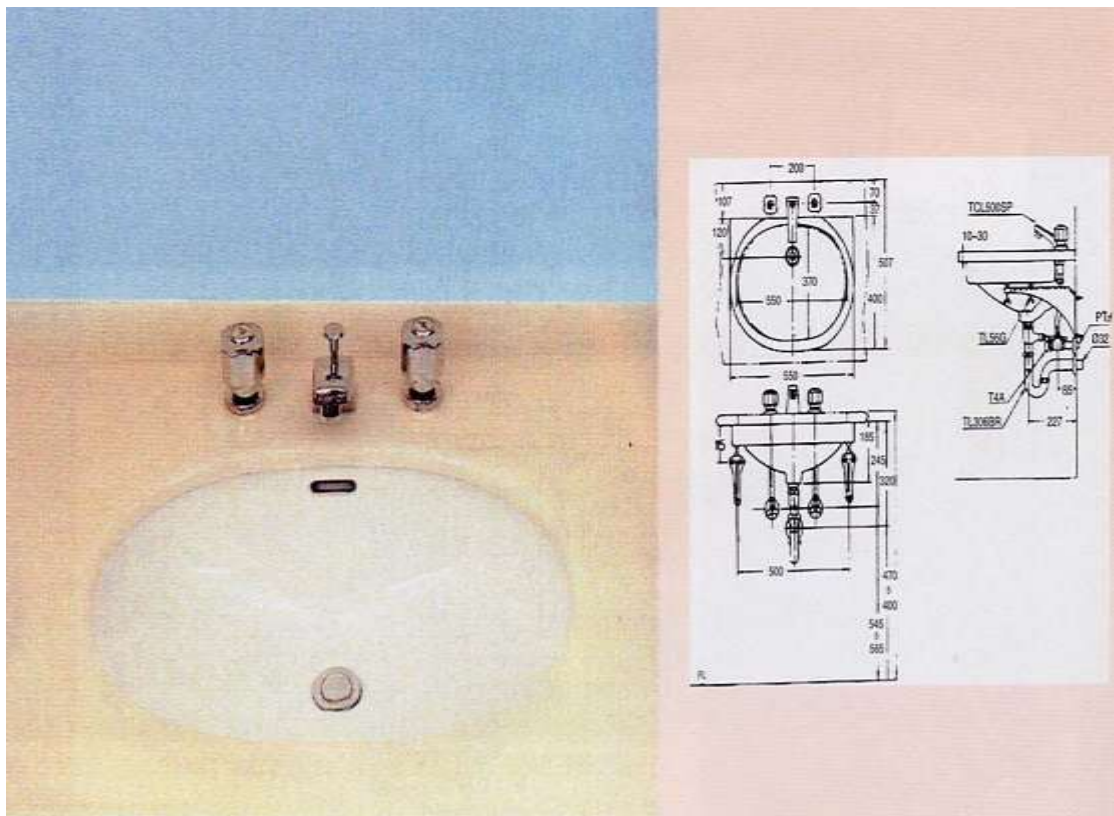
*Illustration 12: Untouchable Square*

*Conveniently sized receptacle offers maximum flexibility so that it can be used in virtually every area of your facility. No-touch lid funnels trash into container, keeping floor free of debris.*

**A Guide to Better Public Toilet Design and Maintenance**  
Sixth Edition 2025

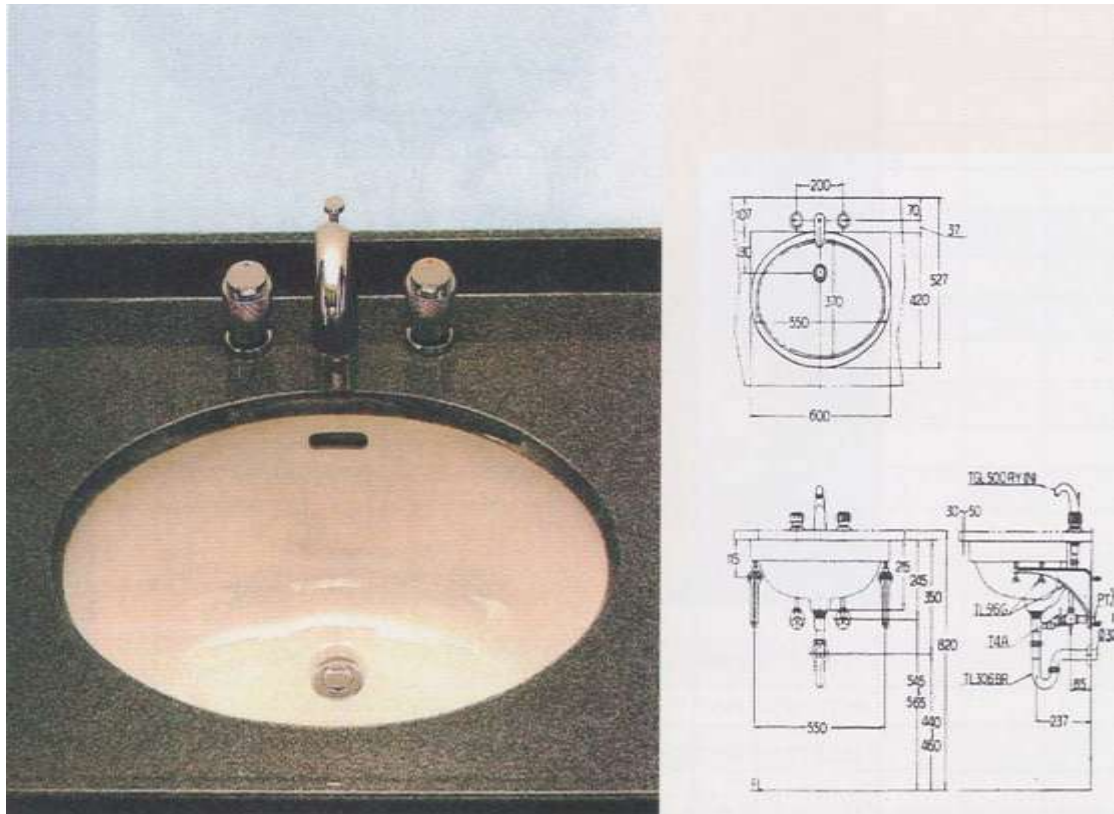


*Illustration 13: Under counter wash basin*

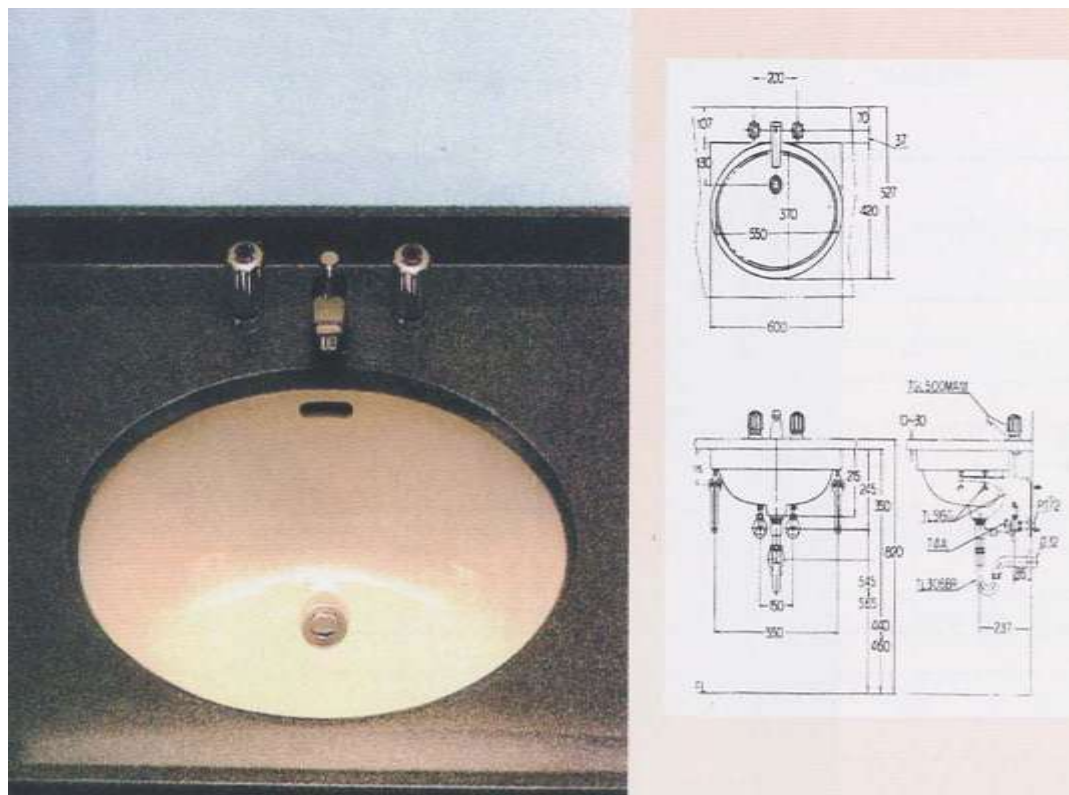


*Illustration 13.1: Under counter wash basin*

**A Guide to Better Public Toilet Design and Maintenance**  
Sixth Edition 2025



*Illustration 14: Vanity top with back splash and apron edge*



*Illustration 14.1: Vanity top with back splash and apron edge*

**A Guide to Better Public Toilet Design and Maintenance**  
Sixth Edition 2025



*Illustration 15: Standalone wash basins (without vanity tops) and scupper drains with metal grating*

**A Guide to Better Public Toilet Design and Maintenance**  
Sixth Edition 2025



*Illustration 16: One-stop provision of auto sensor tap, soap dispenser, litter bin and paper towel dispenser or electronic hand-dryer at wash basin area.*



**A Guide to Better Public Toilet Design and Maintenance**  
Sixth Edition 2025



*Illustration 17: Wall hung WC with double-roll toilet paper dispenser and foot operated sanitary bin*



*Illustration 18: Double hooks provide users with the convenience of hanging personal belongings such as handbags and any extra clothing*

**A Guide to Better Public Toilet Design and Maintenance**  
Sixth Edition 2025



*Illustration 19: Accessible Toilet*



*Illustration 20: Baby Seat*

**A Guide to Better Public Toilet Design and Maintenance**  
Sixth Edition 2025



*Illustration 21: Diaper changing station (closed)*



*Illustration 21.1: Diaper changing station (opened)*

**A Guide to Better Public Toilet Design and Maintenance**  
Sixth Edition 2025



*Illustration 22: Dual adult and child seat cover*



*Illustration 23: Signages for cubicle doors to indicate sit or squat-type WCs*

**A Guide to Better Public Toilet Design and Maintenance**  
Sixth Edition 2025



*Illustration 24: Low level mechanical exhaust*

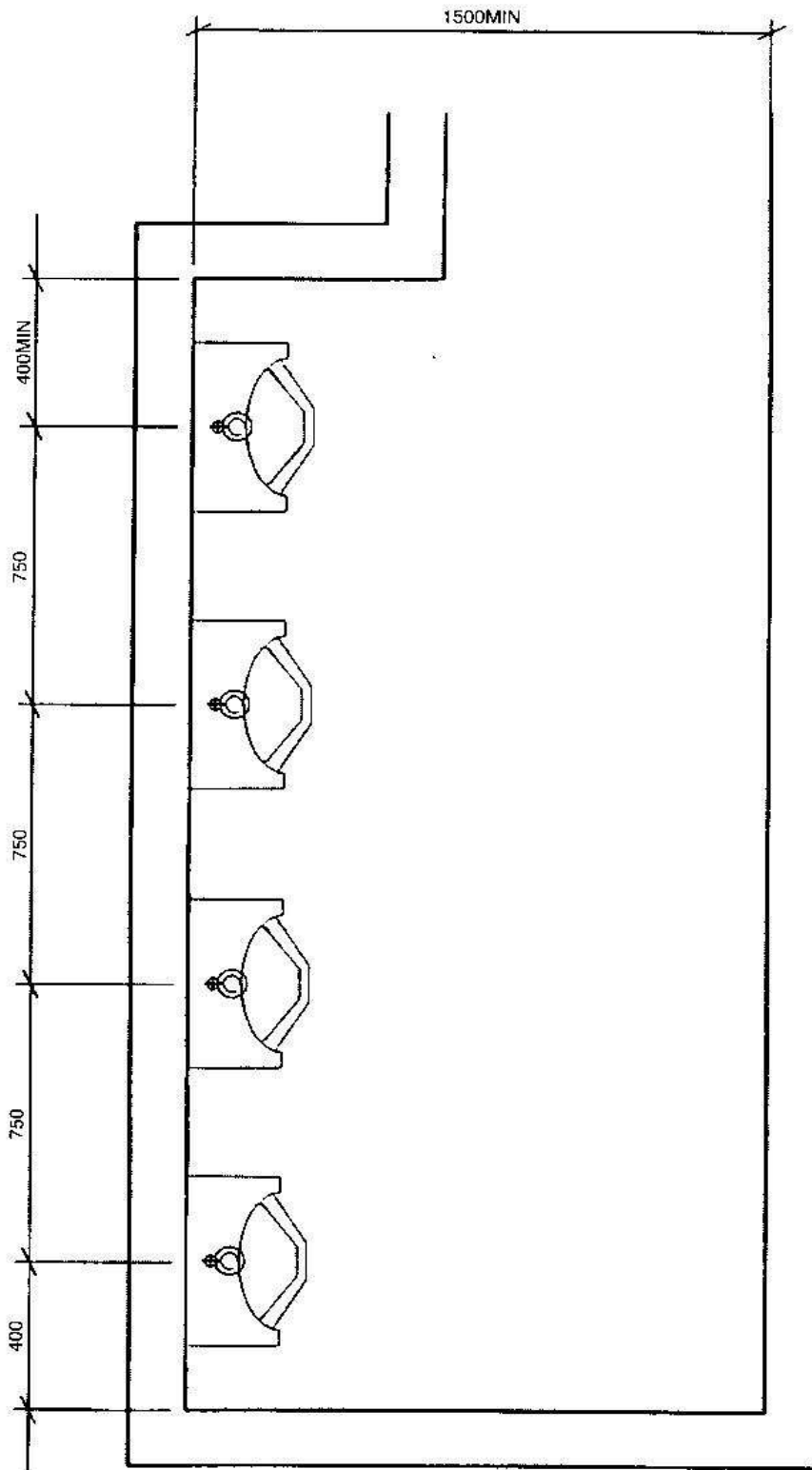


*Illustration 25: Pictorial Guide on Washroom Cleaning Procedures*

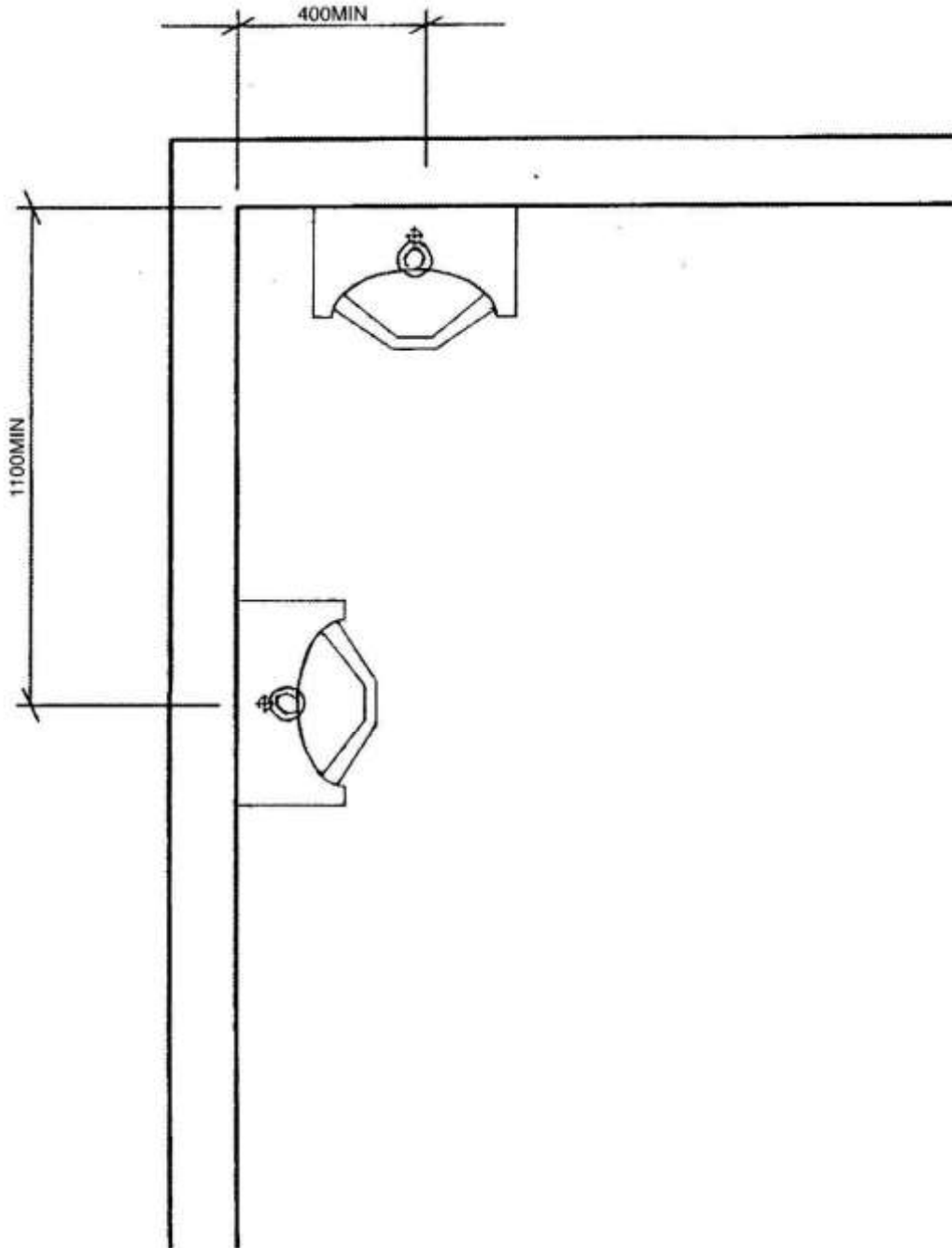


# **APPENDICES**

# **APPENDIX I**

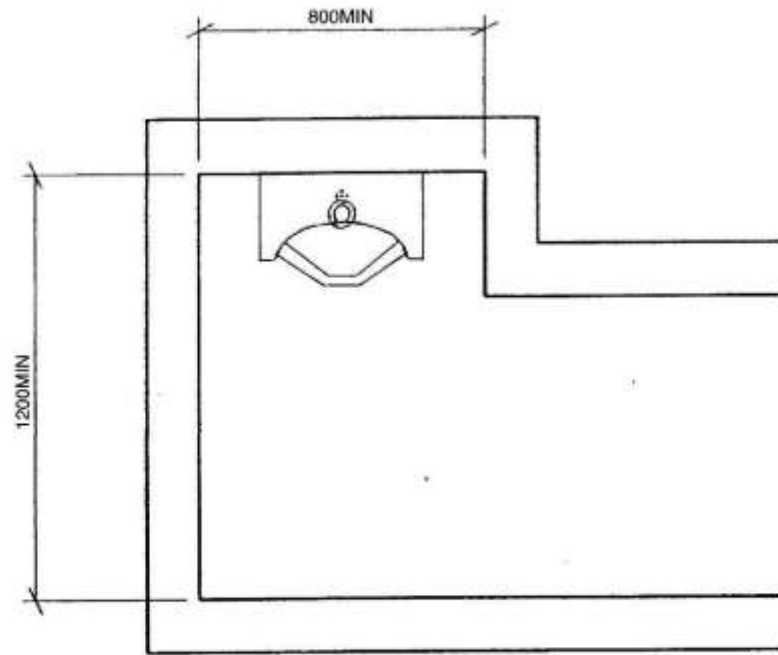


MULTIPLE URINAL

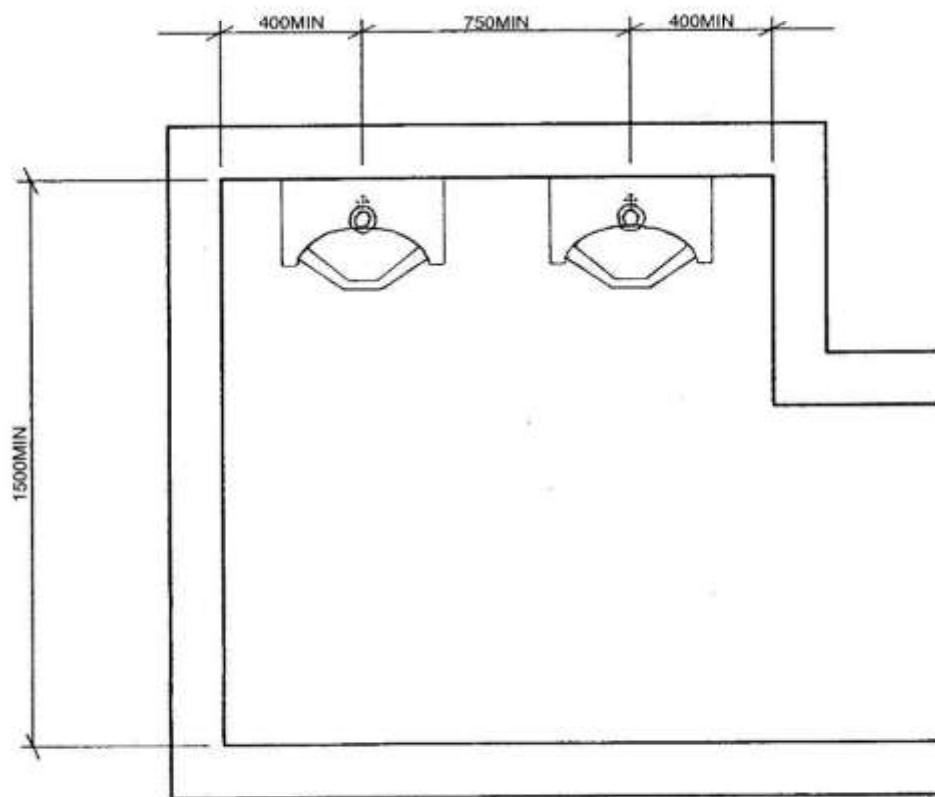


URINAL IN RIGHT ANGLE

**A Guide to Better Public Toilet Design and Maintenance**  
Sixth Edition 2025

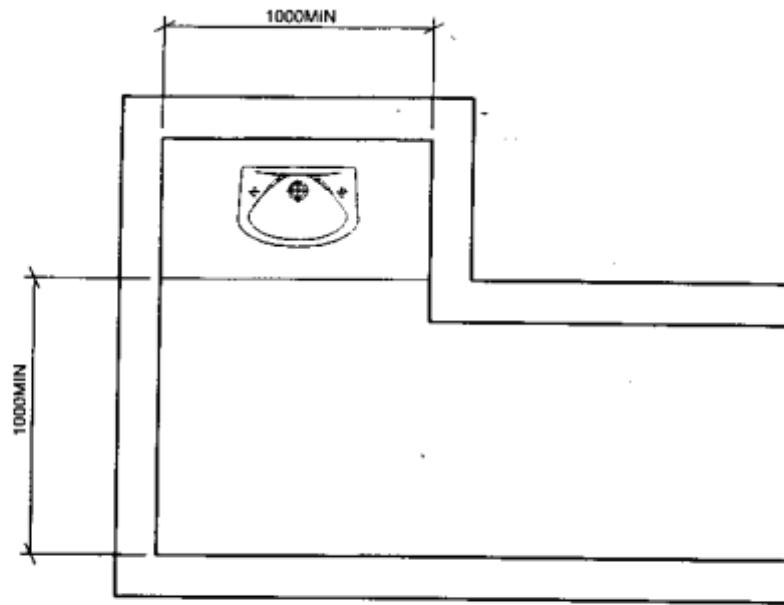


**SINGLE URINAL**

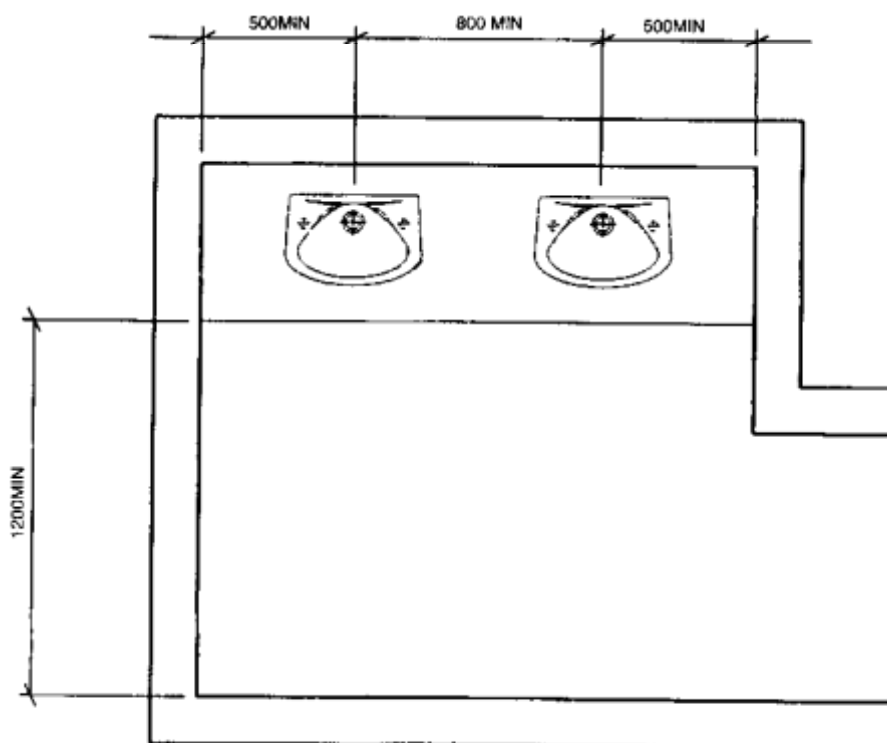


**DOUBLE URINAL**

# **APPENDIX II**

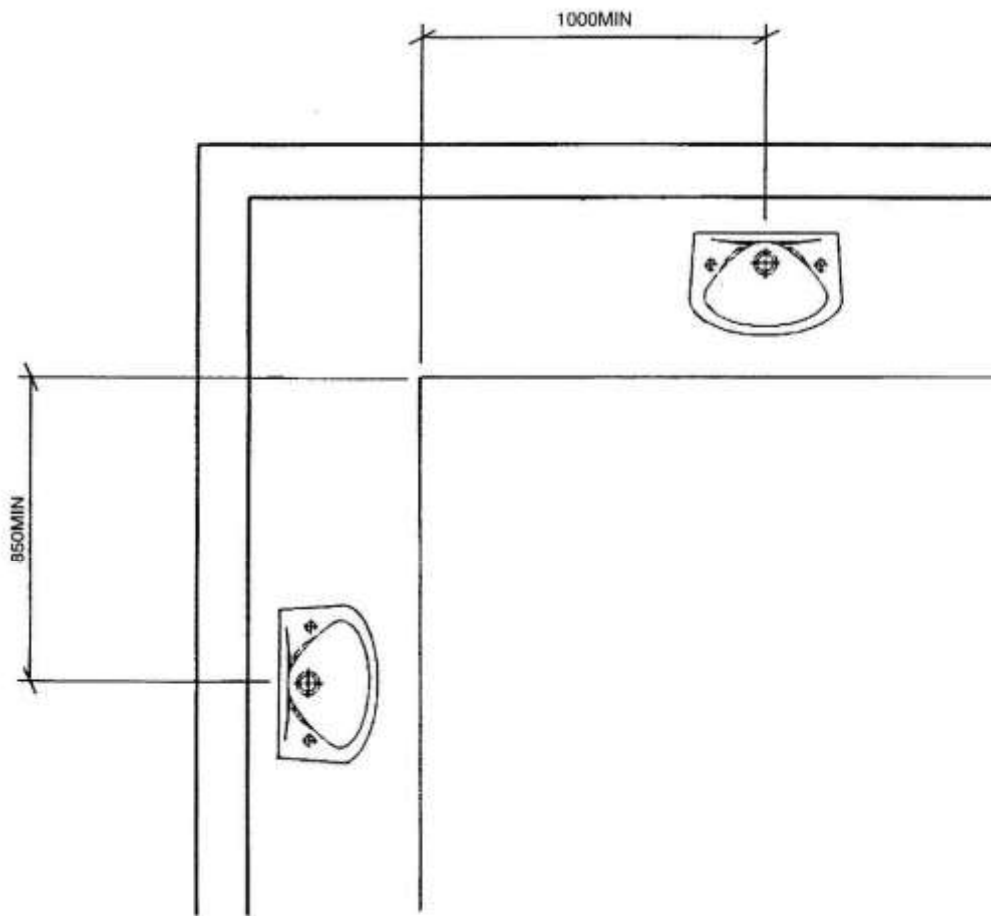


SINGLE WASH BASIN



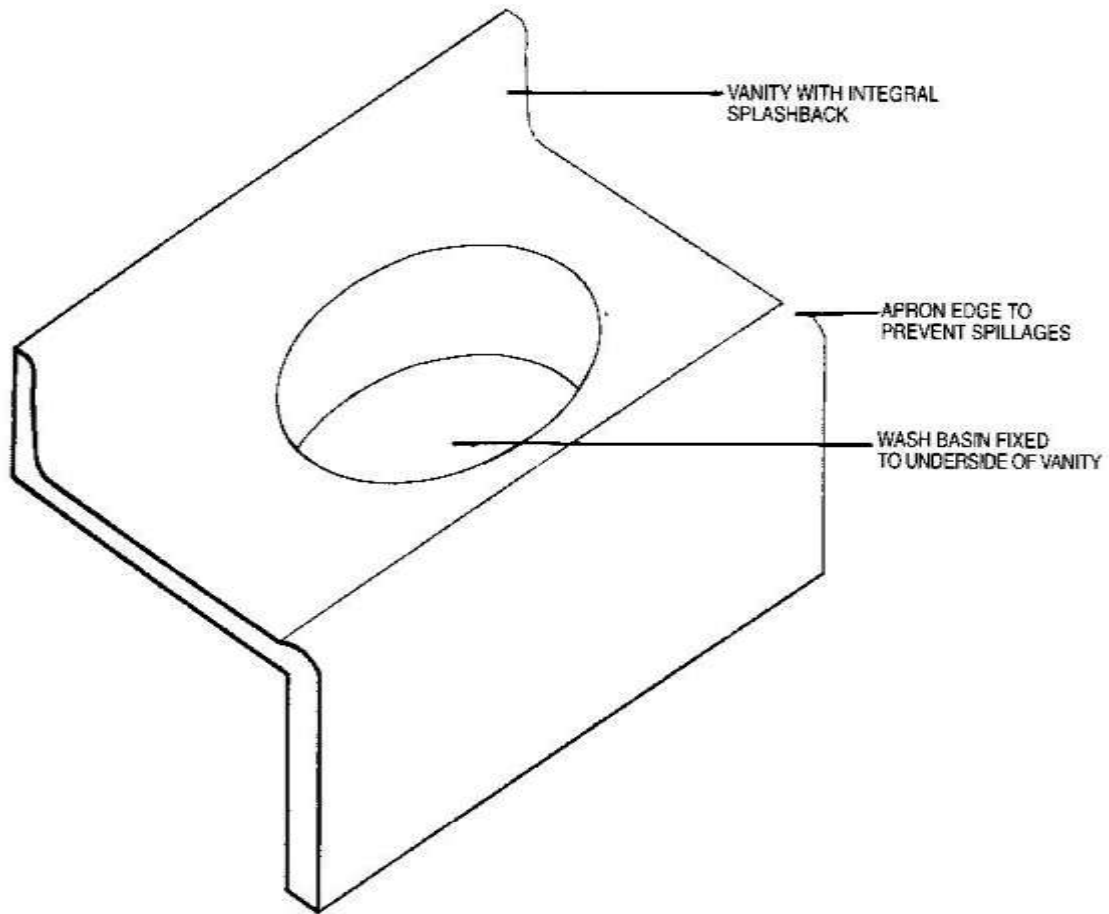
DOUBLE WASH BASIN

**A Guide to Better Public Toilet Design and Maintenance**  
Sixth Edition 2025

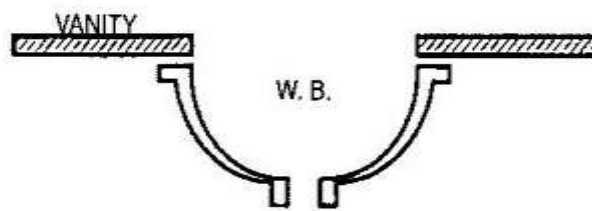


**WASH BASIN IN RIGHT ANGLE**

# **APPENDIX III**



TYPICAL  
VANITY



SECTION

# **APPENDIX IV**

## **Ventilation Fan**

### **Introduction**

A good ventilation fan of a public toilet must not only manage odours but also properly vent hot, moist air that builds up. Ineffective ventilation can make a public toilet unbearable, even if it is well designed. The humid air can lead to mould, cause corrosion to fixtures, and even damage painted and wooden surfaces. A ventilation fan can effectively extract excess moisture to circumvent these risks.

It is found that the floor under and near to the hand-washing area is often in wet conditions. The problem is more obvious when the hand dryers are located at a distance from the hand-washing area. This is because many toilet users do not use the hand dryers and just discharge excess water from their hands by shaking. To tackle this problem, replacement air should preferably be discharged close to the floor level near the wash basins to help keep the floor dry.

### **Product Features**

An ideal ventilation fan for use in the toilet should be (but not limited to):

- x Energy efficient
- x Quiet in operation for proper ventilation
- x Easily accessible via a terminal block for simple wiring
- x Maintenance free where possible
- x Using a fan motor fitted with standard thermal overload protection

### **Product Benefits**

A ventilation fan will ensure better circulation of air in the building by driving out odours and encouraging the influx of fresh air in. As a result, comfort in the toilet will be enhanced. This will help maintain proper hygiene, which is essential in all toilets.

# **APPENDIX V, VI, VII & VIII**

**A Guide to Better Public Toilet Design and Maintenance  
Sixth Edition 2025**

APPENDIX V

<b>PERIODIC CLEANING SCHEDULE</b>		
<b>ITEM</b>	<b>ACTIVITY</b>	<b>FREQUENCY</b>
Floor	Machine scrub to ensure removal of soil from grouting	Fortnightly
Walls	Hand scrub to ensure removal of soil from grouting	Monthly
Bins	Hand scrub to ensure removal of soil from grouting	Fortnightly
Basins	Scrub with scrubbing pad to remove stubborn stains	Weekly
Bowls/Urinals	Scrub with scrubbing pad to remove stubborn stains	Weekly
	Scrub beneath rim to ensure removal of yellow stains	
Soap Dispensers	Dismantle and check/clear chokes	Weekly
Exhaust Fans	Wipe clean to remove dust	Weekly

**APPENDIX VI**

<b>FREQUENCY OF CLEANING</b>	
Light Industry Building	once or twice a day
Condominium	twice a day and increase to 4 times a day during weekend
Office Building	4 to 5 times a day
Hotel	6 times a day
Shopping Centre	6 to 8 times a day
Hawker Centre	1 to 2 hourly cleaning during non peak hours every 1/2 an hour cleaning during peak hours

**NOTE:**

The above frequencies refer to thorough cleaning once a day and spot cleaning for the remaining "cleans". E.g. the frequency of cleaning toilets in hotel is six times a day. This is equal to one thorough cleaning plus five spot cleanings a day.

**APPENDIX VII**

<b>EQUIPMENT AND SUPPLIES LIST FOR CLEANERS</b>	
1)	Service tray or cart
2)	Premixed glass cleaner (with spray bottle)
3)	Premixed disinfectant cleaner (with spray bottle)
4)	Disinfectant cleaner concentrate
5)	Scouring power
6)	Stainless steel cleaner (if necessary)
7)	Toilet bowl swab and container
8)	Putty knife
9)	Broom
10)	Dust-pan corner brush
11)	Mop/bucket/wringer
12)	Signages such as 'wet floor' and 'closed for cleaning'
13)	Duster (feather/lamb's wool)
14)	Clean cloth
15)	Paper towels/toilet paper/soap
16)	Gloves

**APPENDIX VIII**

<b>CLEANING AGENTS FOR DIFFERENT FINISHES</b>	
1) Wall/Floor (ceramic, granite and marble tiles)	Use neutral-based cleaners or disinfectants. Do not use acid-based cleaner on marble
2) Glass/Mirror	Use ammonia- or neutral-based cleaners
3) Sanitary Wares	Use disinfectant cleaners
4) Stainless Steel/Chrome	Use stainless steel/chrome polish
5) Plastic/PVC	Use neutral based cleaners
6) Toilet Bowls	Use disinfectant or mild abrasive liquid cleaners

# **APPENDIX IX**

## **Sensors**

### **Smart Lighting Sensor**

When there is no human movement, movement sensors in LED lightings will automatically dim the lightings from 300 lux to 50 lux instead of turning them off completely. This ensures energy efficiency without compromising on safety.

### **Smart Ventilation Sensor**

When the ammonia level threshold is not within acceptable limits, the ventilation fan will be automatically turned on. The fan will also be turned off when the ammonia level is within acceptable limits. Apart from good ventilation, the air pressure in the toilet is a key factor in the determination of the air flow which will either expel or trap the odour. Therefore, an air pressure test should be conducted for newly-constructed toilets.

### **Smart Water Sensor**

A real-time Graphical User Interface (GUI) that continuously monitors water usage and will notify owners and facility maintenance crew of any abnormal flow and usage. This will help to detect any pipe and tap leakages, urinals and toilet bowls that are constantly flushing, etc, thus allowing for faster rectification and reducing water wastage.

### **Smart People and Ammonia Sensors**

A people traffic with ammonia detection system which sends a notification alert when a pre-determined number of people i.e. high traffic or ammonia level is reached. This real-time Graphical User Interface (GUI) helps to improve the productivity and efficiency by remotely monitoring the cleanliness status of restrooms so that maintenance management and cleaning crew can be deployed when necessary rather than at fixed intervals. This system also allows effective monitoring on usage across multiple restrooms. Through analysing the data collected, resources can be better allocated ahead of time based on usage patterns.

### **Smart Amenities**

Basic amenities namely hand soap, hand towels and toilet paper can be effectively monitored and notification alerts are generated when the items need to be replenished. Notification alerts are also generated when the amenities are either empty or full. An innovation available in the market allows for the dispensing of hand soap through a centrally located soap reservoir pumped to multiple dispensers automatically when volume is low. Such a system, typically hidden behind vanity tops, consist of a reservoir tank, pumps and individual dispensers - all of which are built with sensors facilitate the

## **A Guide to Better Public Toilet Design and Maintenance**

**Sixth Edition 2025**

automatic replenishment of soap. This reduces the need for cleaners to manually check the dispensers and perform daily top ups.

### **Manage cleanliness in real-time with Bin Fill-level Sensor**

Reduce waste collection trips with waste level tracking. Ordinary waste containers are transformed into smart-bins through the installation of Internet of Things (IoT) sensors. This allows staff to perform remote monitoring and schedule tasks whenever the bin is full, improving labour efficiency while ensuring premises are kept clean.

#### Advantages of IoT Enabled Bins x

##### Save Time & Labour

- x With an automated bin system, staff do not have to constantly check waste bin levels, can also be operated remotely, thereby reducing manual labour.
- x Improve efficiency and productivity
- x Sensors ensure bins are packed to the brim before alerting on waste collections, improving waste compaction while saving time on bin collection trips.
- x Improve planning with Data Insights
- x Staff can determine hotspots with overflowing bins. Derived data can be used for predictive analysis and improved decision making, such as optimising bin collection timings and bin locations.

#### IoT Enabled Bin Features

- x The sensor components consist of a laser sensor for monitoring bin waste levels, and an odour sensor to alert on collections and prevent pest attractions.
- x Low Battery Notifications
- x The waste bin battery will automatically send an alert to the monitoring system if the power is running low, ensuring the uptime of the IoT devices.
- x Task Automation
- x Live monitoring of waste levels reduces waste collection trips and saves manual labour by offering remote control of operations and maximises waste compaction.
- x Accurate & Compatible
- x The IoT sensors can detect changes in waste levels and odours reliably, are compatible with any bin or container and can monitor any waste type in real-time.

#### How it works

Bin fill level and/or odour sensors are installed on bins =====>Bin fill level data is collected and transmitted to the cloud-based smart waste management platform=====> Staff can monitor data live from the dashboard and the system will alert staff to collect its waste when the bin is full.

# **APPENDIX X**

## **Interactive Feedback System**

### **Introduction**

The feedback system should be preferably developed in accordance with the Happy Toilet Programme administered by the Restroom Association (Singapore) including the following specifications:

### **Web-based, hosting and security requirements for better stability and reliability**

- x Support major web browser primarily Microsoft Edge, Google Chrome and Apple Safari x Zero installation that does not require third party add-ons, plug-ins or ActiveX components
- x Supports secure cryptographic protocol of TLS 1.2 or better
- x Expandable and extendable platform catering for the growth and future expansion through instant upgrade of relevant components without having to compromise on the system performance or changing the design and configuration of the proposed system
- x Cloud hosting and storage service shall be assessed and registered with Infocomm Media Development Authority (IMDA) Level 3 (IaaS) compliance x The system shall meet best industrial practice with the following requirements to run 24 hours x 7 days x Equipped with appropriate end point security and uninterruptable power supply to protect against power loss
- x Cloud hosting shall be secured with appropriate end point security software or appliance

### **User interface for better data collection and analysis**

The Graphical User Interface (GUI) design should be: x User friendly in visual appearance, colour separation, interactive behaviour and layout should be consistent and easy for the general users with minimal training

- x Report with various key filters shall be easily generated from the system which can then be downloaded in Microsoft Excel format (xls, xlsx)
- x All data shall be visualised in graphical formats such as pie chart, line chart, bar chart, stacked Chart with various key filters suitable for the user
- x Charts should be exportable to other formats such as JPEG, PNG and PDF x Chart's data shall be exportable as csv or xlsx formats

### **Touch panel for better durability and functionality**

Hardware

- x Preferably at least 10-inch class display/touch panel with security lock and key

## **A Guide to Better Public Toilet Design and Maintenance**

**Sixth Edition 2025**

- x Green and eco-friendly hardware with low power consumption
- x Supports wireless data transmission via WIFI or public cellular network
- x Corrosion resistance from water and common cleaning agents
- x Panel shall be easily visible against mounting wall with no sharp edges or corners to prevent accidental injuries
- x All wirings shall be concealed
- x Programmable boot-up and shutdown schedules

### Software and firmware

- x Secured against malicious cyber-attacks with recognised certification
- x Restrict installation permissions to only approved software
- x Support remote configuring and monitoring of data connectivity, power supply and other essential system parameters

### Primary function of touch panel

Allows public to provide feedback

- x Able to display cleaners' photo profile with rating scale of 4-5 smileys with a simple touch selection
- x Able to select specific items to provide feedback on, e.g., wet floor, dirty toilet bowls, etc
- x Allows the cleaning crew to perform electronic check card/checklist
- x Allows the cleaning crew to review and close any negative feedback cases that has been resolved
- x Able to notify the respective team(s) with jurisdiction over the type of issue reported
- x Provides a feedback dashboard for review of each open-ended feedback and;
- x Allows owners, operators and cleaning companies to view details of feedback received
- x Allows owners, operators and cleaning companies to address and resolve feedback
- x Provides data analytics to allow owners, operators and cleaning companies to generate report on historical and current feedbacks based on key identifiable attributes such as by staff, date/time, etc.

### **Support QR code feedback for alternative choice of feedback**

This is to supplement the touch panel as public may prefer to use their own smart device to leave feedback as follows:

- x Allows the public to scan a QR Code to leave feedback via their own smart devices
- x Solution shall allow owners, operators and cleaning companies to print such QR Codes at their own capacity with reasonable ease
- x Web apps shall be optimised for mobile use and provide support for iOS and Android devices

# **APPENDIX XI**

## **Coating Treatment for Sanitary Fixtures**

### **Introduction**

Coatings applied should preferably be one approved by the RAS, which fits the general requirements of a toilet. Coating treatment usually comes in the form of an air-dried, clear, colourless treatment for floor tiles, ceramic sanitary fixtures and glass surfaces. The industry offers such coating solutions which could either be manufactured into the building materials for durability and reliability or coated on after production. Such a coating can be used to improve the cleanliness and hygiene of a surface by preventing dirt sticking onto the surfaces and eliminating odour formation in targeted areas such as underneath urinals. Fluoropolymer is a known coating material that can react with the surface to create a low surface energy coating, which is not easily wetted with liquids/oil. The treatment should be stable and resistant to removal.

The treated surface should be durable, highly repellent to oils and water and does not change surface appearance. By having such coating on sanitary fixtures in the toilet, we can potentially reduce the frequency of cleaning in the toilet and increase the hygiene standards.

### **Product Features**

#### **x Durability**

The coating should last at least 10, 000 wipes or more, and up to 3000 scrubs under the ASTM D2486 standard. Such coating can typically last from 3 – 5 years depending on usage conditions.

#### **x Resistant to Tough Stains**

The coating should be both hydrophobic and oleophobic, meaning it is effective not only towards water-based stains but also oil based stains. The nature of stains found in bathroom usually varies, from human waste to cosmetics. A coated surface would prevent most types of difficult substances from causing permanent stains.

#### **x Surface Protection**

Discolouring or yellowing of sanitary wares are usually due to the porosity of ceramics, where stains are entrenched into these pores, making them irremovable. This can be due to the wear and tear of the glazing layer, exposing the pores of the ceramic wares. The coating would act as an additional layer of protection, prolonging the lifetime of our ceramic sanitary ware.

#### **x Environmental Sustainability**

## A Guide to Better Public Toilet Design and Maintenance

Sixth Edition 2025

The most common method to solve a difficult stain issue, is to use harsher chemicals, such as bleach or even acid. These chemicals pose problems both to the environment and personnel handling them. With a coated surface, one can possibly reduce the use of such chemicals and contribute to a sustainable environment.

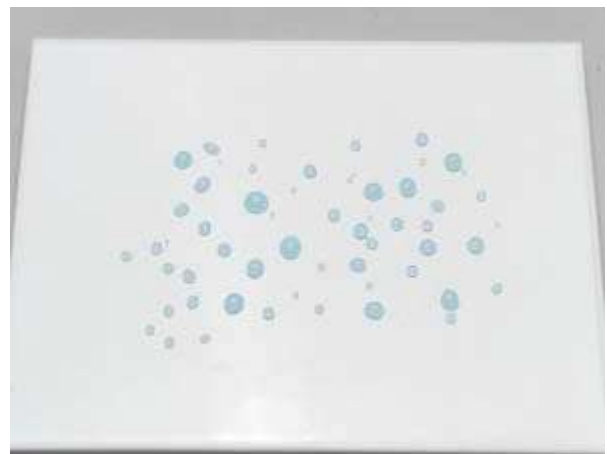
### x Increased Productivity

In a commercial setting, with large number of toilets and high human traffic, cleaning is usually a time consuming and tedious job. With less difficult stains to remove, cleaners can potentially spend less time cleaning when such a coating is applied.

**Before Coating**



**After Coating**



# **APPENDIX XII**

## **UV-C Disinfecting Lighting Technology**

### **Introduction**

UV-C systems can disinfect air and surfaces to eliminate and reduce bacteria, viruses and spores. Use of such systems should be certified by the accredited SAC-SINGLAS (The Singapore Laboratory Accreditation Scheme) Laboratories to ensure the system is safe and reliable without exposing them to human.

### **Automated & Labour Saving**

System performs automatically in the background without any disruptions to operations. Automated disinfection reduces reliance on labour.

### **Sensors**

The system has proximity sensors and human sensors to ensure automated and safe operations.

### **Green & Eco-friendly**

The system uses little energy (less than 10 Watts average) and is mercury-free and chemical-free. Disinfecting lighting technology reduces resources for consumables.

### **Specifications**

Products should preferably be from a reputable source with patent rights. CE mark and IEC 62471 Exempt Category (No Photobiological Hazard)

# **APPENDIX XIII**

## **Self-powered Taps**

### **Introduction**

Such system incorporates two technologies into a single tap that helps the building owners reduce installation hassle as well as reap energy savings.

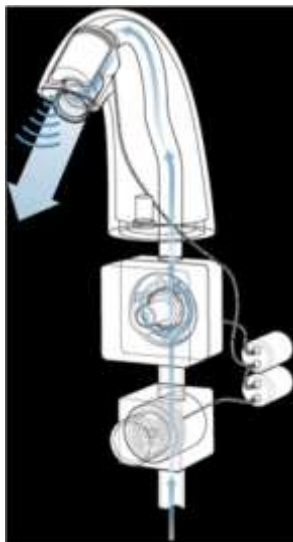
### **Product Features**

The system uses a micro sensor positioned at the tip of the spout to aid in the sensing of hands. The tap body is fitted with a small generator that harnesses the energy from water flowing through the tap to make the micro sensors energy self-sufficient.

The tap body is also fitted with a lithium-based battery that is able to store power generated to power the micro sensor for subsequent use.

### **Benefits**

The use of a micro generator will eliminate the hassle of expensive AC wiring and complicated installation. It is also an environmentally-friendly solution that helps to generate power from the tap's operation, encouraging sustainability in conserving energy while also leading to cost savings.



# **APPENDIX XIV**

## **Fast-drying Hand Dryers**

### **Filter**

- x Preferably equipped with a high quality HEPA media to ensure clean and hygienic air

### **Operation**

- x Touch free operation
- x Hand dry time measurement between 10 to 15 seconds (should preferably be tested and certified by an independent organisation accredited by the Singapore Accreditation Council (SAC) or the NSF International) x
- Operation lock-out period: 30 seconds

### **Technical specification**

- x Preferably made of durable materials such as polycarbonate against knocks and shocks. Preferably carbon trust certified

### **Energy-saving accreditation**

- x Preferably by Singapore Environment Council or Singapore Green Building Council

# **APPENDIX XV**

## **Modern Waterless Urinals**

### **Cleaning and maintenance**

- x Urinal traps for the urinals shall be accessible for maintenance, yet be airtight sealed during normal operations. When necessary, a waterless drain trap can be installed to allow for mopping of the floors but seal away sewer gases from the drain.
- x The urinal shall support swift maintenance procedure to remove foreign objects in the bowl, outlet and wastepipe without dismantling the system (due misplaced paper towels, urine stone etc.)



### **Design**

- x The design shall cater for minimal spill-back and not expose any collars, rinsing channels and hidden openings that are vulnerable to urine deposits and soiling over time
- x No collars, opening rinse channels etc. for easy cleaning and avoidance of deposit build-up
- x Preferably light-weight and more resistant to damage like UV stabilised polycarbonates or similar materials

### **Ecological, health & safety considerations**

- x Cleaning detergents shall be harmless to the cleaning crew and public users (no harsh chemicals and sanitisers causing skin irritation on exposure), certified biocompatible and biodegradable. At the same time, cleaning detergent shall control for smell and bind any ammonia emission.
- x There are microbiological cleaning detergents that deploy micro-organisms to penetrate the pores (joints) and eliminate any odours caused by organic residues deposited there. Used regularly, it contains and prevent odours from developing.

# **APPENDIX XVI**

**APPENDIX XVI**



**Her childhood is at stake.  
And you're the cause of it.**

The little angels  
Always cheerful and lively  
But due to our negligent habits in the toilet  
Leaves them vulnerable to bacteria and germs  
Viruses particularly hand-foot-mouth disease will invade  
With no awareness  
Their happy childhood might be at stake  
Their joyful expressions might vanish  
The little angels deserve better, much better

Show a little consideration and responsibility  
It makes a big difference



Website: <http://www.raa.sg>



**They're losing their appetite.  
And you're the cause of it.**

Earning just \$800 a month  
They work exceedingly hard for their rice bowls  
But due to our negligent habits  
They are not enjoying what they slog to keep  
Their jobs are courageously tough  
Restroom cleaners deserve better, much better  
Don't make them do more than their jobs require  
Keep their workplace clean and dry  
Have them look forward to their meals

Show a little consideration and responsibility  
It makes a big difference



Website: <http://www.raa.sg>



**They're diagnosed with health problems.  
And you're the cause of it.**

Turning away from unhygienic and dirty toilets  
Some would rather hold their bladder  
With much possibilities of having kidney problems  
And bladder malfunction  
Stop these agonizing consequences  
These people deserve better, much better  
Don't make their lives difficult  
Keep the toilets clean for everyone's usage

Show a little consideration and responsibility  
It makes a big difference



Website: <http://www.raa.sg>



**An average person spends 3 years of their lives in a toilet**

Have fun the **RIGHT** way

**READY**

**AIM**

**RESET  
(FLUSH & CLEAN UP)**

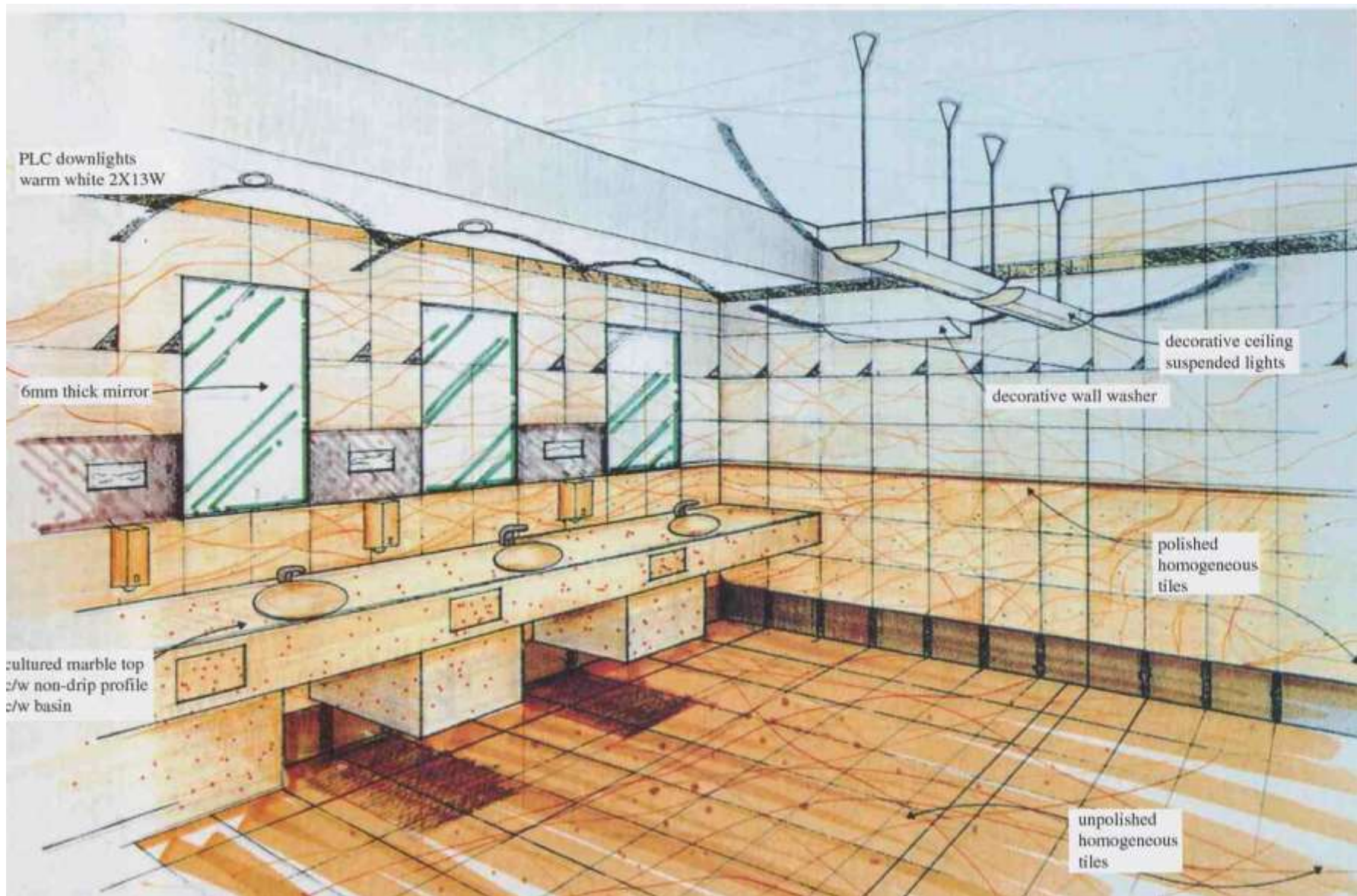


Restroom Association (Singapore)  
Website: <http://www.raa.sg>

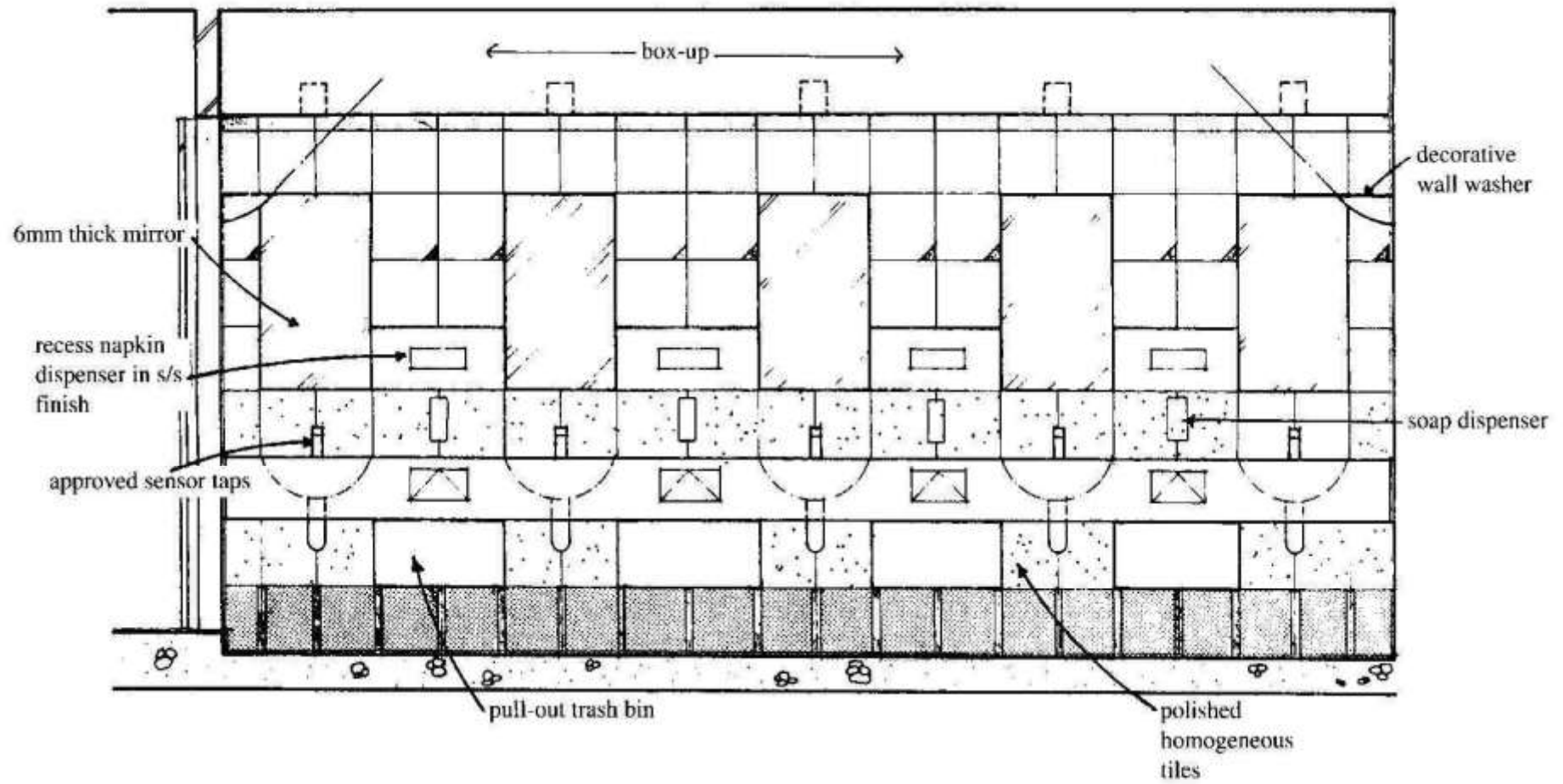
# **SUGGESTED LAYOUT OF PUBLIC TOILETS**

# A Guide to Better Public Toilet Design and Maintenance

Sixth Edition 2025

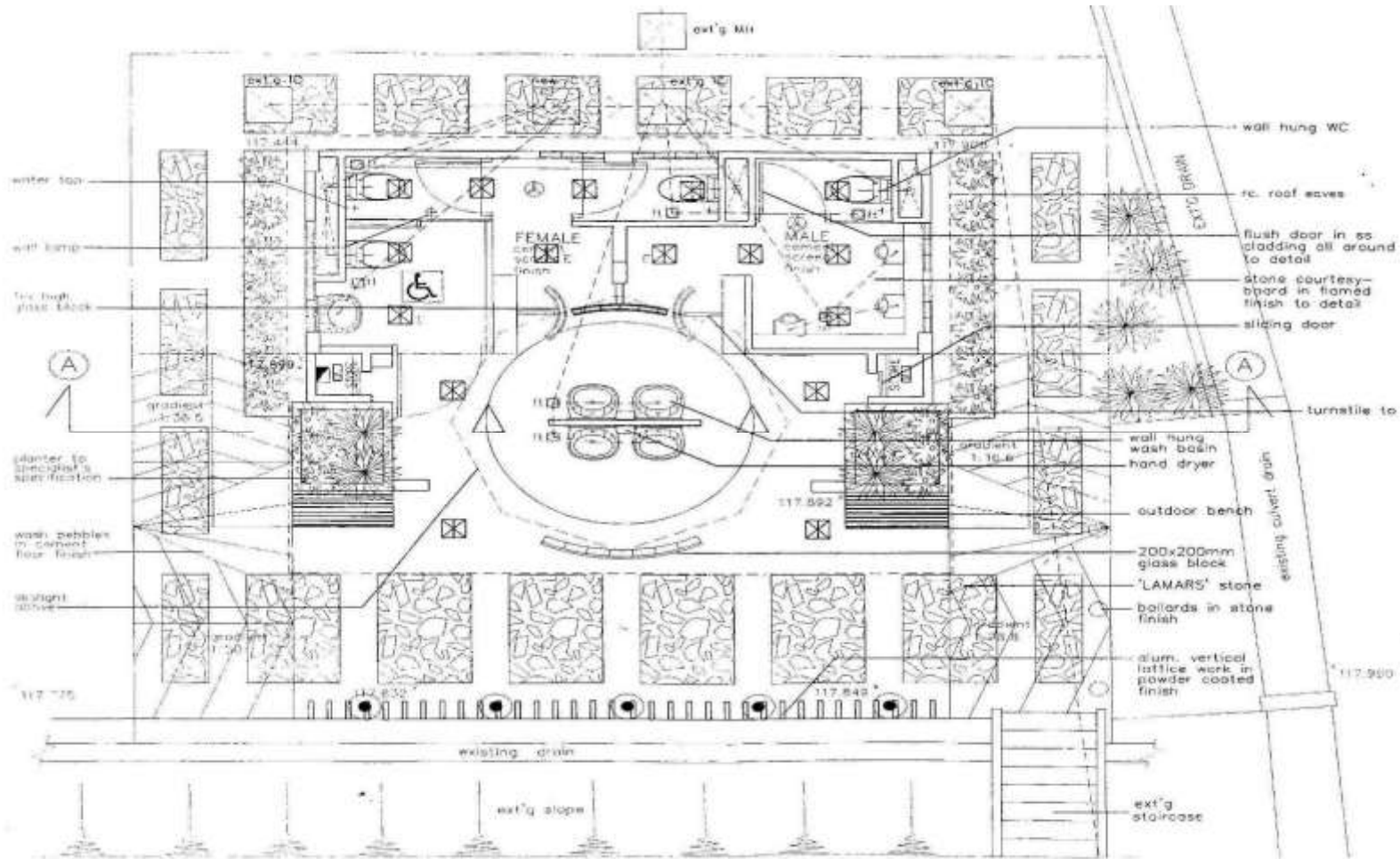


**A Guide to Better Public Toilet Design and Maintenance**  
Sixth Edition 2025



**ELEVATION**

**A Guide to Better Public Toilet Design and Maintenance**  
**Sixth Edition 2025**



**Holland Road Market Toilet**

# **DO'S AND DON'TS IN DESIGNING TOILETS**

DO'S

Use of task lighting, down lighting, colourful tiles and colourful artworks to create ambience.



a. Task Lighting  
b. Down Lighting

a. Colourful Artworks

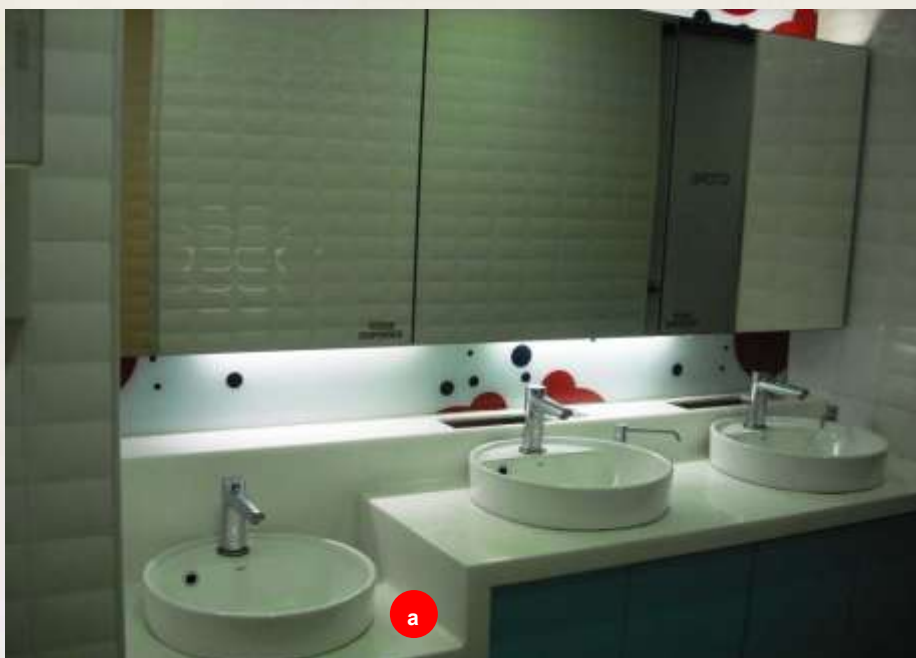


a. Colourful Tiles

Provision of modesty boards; wash basin at child height.



a. Modesty Board



a. Wash Basin at Child Height.

DO'S

Example of features and amenities that should be found in the toilets of coffeshops.



- a. Sensor Flush
- b. Toilet Paper Dispenser
- c. Litter Bin



- a. Soap Dispenser
- b. Back Splash
- c. Wash Basin Rim below Vanity Top
- d. Vanity Top
- e. Apron Edge
- f. Hand Dryer

DO'S

Correct positioning of soap dispensers, hand dryers and waste bins



- a. Soap Dispenser
- b. Waste Bin
- c. Hand Dryer

Intake grilles at low levels near W.C.s.



a. Intake Grilles



a. Intake Grilles

**DON'TS**

Wrong positioning of mirrors and absence of modesty boards.



Absence of vanity top; exposed pipeworks, surface mounting of cables; urinals of inadequate size.



a. Absence of Vanity Top  
b. Exposed Piping

c. Surface Mounting of Cables



**DON'TS**

Presence of painted surface; exposed piping; no apron edge to vanity top and basin rim projecting above vanity top.



a. Painted Surface  
b. Exposed Piping



a. Basin Rim Projecting Above Vanity Top  
b. No Apron Edge

# **ANNEX FOR SAFE TOILETS**

# A Guide to Better Public Toilet Design and Maintenance

## Sixth Edition 2025

Physical Crime [Not limited to SPF's posters]	Scams
<div data-bbox="300 360 517 636"> <p><b>DON'T BE A PEEPING TOM, YOU WILL BE ARRESTED!</b></p>  <p><b>THE WRONG ACTION: PEEPING ON OTHERS</b></p> </div> <div data-bbox="521 360 738 636"> <p><b>Be Aware of Your Surroundings</b></p>  <p><b>Mohammed is a <b>CRIMINAL</b></b></p> </div> <div data-bbox="743 360 986 636"> <p><b>DON'T BE A PEEPING TOM, YOU WILL BE ARRESTED!</b></p>  <p><b>THE WRONG ACTION: PEEPING ON OTHERS</b></p> </div> <div data-bbox="284 674 571 860"> <p><b>NOTICE</b></p>  <p><b>PLEASE TAKE CARE OF YOUR PERSONAL BELONGINGS</b></p> </div> <div data-bbox="619 674 1018 884">  <p><b>KEEP YOUR BELONGINGS SAFE</b></p> <p><b>KEEP YOUR BELONGINGS SAFE</b></p> <p><b>KEEP YOUR BELONGINGS SAFE</b></p> </div>	<div data-bbox="1086 360 1278 591"> <p><b>Unsure if it's a scam? Call 1799</b></p>  </div> <div data-bbox="1283 360 1474 680"> <p><b>BEWARE OF THE IMPOSTORS</b></p> <p>Police officers will <b>NEVER</b> ask you for the phone or text message for:</p> <ul style="list-style-type: none"> <li>• Transferring to any public bank accounts. (It needs number and the bank name)</li> <li>• Payment for your money, to help in the relief of disaster.</li> <li>• Check on the bank card to make sure.</li> </ul> </div> <div data-bbox="1107 696 1458 846"> <p><b>Protect yourself with the ScamShield Suite</b></p>  </div>

# **ACKNOWLEDGEMENTS**

# A Guide to Better Public Toilet Design and Maintenance

Sixth Edition 2025

**The Restroom Association (Singapore) wishes to extend its warmest gratitude and appreciation to the following organisations (in alphabetical order) for contributing their expertise, time and effort towards the publication of this fifth revised guide.**

Adsec Systems Pte Ltd  
Ecolab Pte Ltd  
Miredo Asia Pte Ltd  
National Environment Agency  
Singapore Green Building Council

We also wish to extend our warmest gratitude and appreciation to the following professionals for contributing their expertise, time and effort towards the first four publications of the guides.

**1999 First publication:** Mr Yang Mee Loong, Mr Carl Wong, Mr Constantine Pikoulas and Assistant Professor Su-Lin Gan.

**2002 Second publication:** Mr Teoh Hai Pin, Ms Constance Ann, Mr Loke Leong Seng, Mr Jin Sung, Mr Chu Lik Ren, Ms Susana Lim and Mr Osman Bin Mohamed.

**2013 Third publication:** Ms Nikki Shaw, Mdm Goh Siam Imm, Miss Siti Suriani, Mr Ramahad Singh, Mr Tony Soh, Mr Kenneth Loo, Mr Ng Meng Hui and Mr Jack Sim.

**2018 Fourth publication:** Mr Tommy Tham, Mr James Lim, Mr Dennis Quek, Mr Lars Christian Friedrich Eckle, Mr Cedric Hoon, Mr Tony Chooi, Mr Joe Ng, Dr Allen Poh, Ms Irene Toh, Mr Leonard Chiew and Ms Nikki Shaw.

We would like to thank the management of the following buildings (in alphabetical order) for allowing us to use photographs of their public toilets as good examples.

**2002 Second publication:**

Ang Mo Kio Wet Market (Blk 724)  
Causeway Point  
Great World City  
Plaza Singapura  
Centrepoint  
Orchard Point  
Orchard Paragon  
Tanjong Pagar MRT Station

**2013 Third publication:**

AMK Hub  
Dawson Place  
Depot Heights Shopping Centre  
Golden Mile Food Centre  
Fajar Shopping Centre  
Mount Vernon Sanctuary

**A Guide to Better Public Toilet Design and Maintenance**  
**Sixth Edition 2025**

Sunshine Place

**2018 Fourth publication:**

Woodleigh Train Station - SBS Transit

We would also like to thank the following suppliers of toilet facilities and fittings for the use of illustrations and photographs in the third publication.

Inhwa Marketing Pte Ltd

Kimberly-Clark Singapore (Away-From-Home Business)

Million Lighting Company Pte Ltd

**2025 Sixth Edition**

Singapore Police Force